



Service Manual

FOR THE TURBOCHEF ECO ST RAPID COOK OVEN



For further information, call

800.90TURBO

or

+1 214.379.6000

Original Instructions

The information contained in this manual is important for the proper installation, use, maintenance, and repair of this oven. Follow these procedures and instructions to help ensure satisfactory baking results and years of trouble-free service.

Errors – descriptive, typographic, or pictorial – are subject to correction. Specifications are subject to change without notice.

Please carefully read this manual and retain it for future reference.

Table of Contents

Important Safety Instructions

General Safety Information.....	i
Reducing Fire Risk.....	ii
Grounding Instructions.....	ii
Power Cord Replacement or Removal	ii
RF Interference Considerations.....	ii
Precautions to be Observed Before and During Servicing to Avoid Possible Exposure to Excessive Microwave Energy	iii
Protective Earth (Ground) Symbol	iii
Equipotential Bonding Symbol.....	iii

Specifications and Installation

Theory of Operation.....	1
Features	1
Dimensions.....	1
Certifications.....	2
Oven Construction	2
Electrical Specifications.....	2
Installation	2
Unpacking Instructions	2
Installation Warnings – Read Before Lifting Oven.....	3
Lifting and Placing the Oven.....	3
Installation Near Open Heat Source	3
Oven Restraint Kit.....	4
ChefComm Pro	4
Middleby Connect™	4
Registration Prompt.....	4
Voltage Selection.....	4
Ventilation	4

Maintenance

Daily Maintenance.....	5
------------------------	---

Oven Controls and Cooking

Oven Controls	7
Menu Cook Mode	8
Manual Cook Mode.....	11

Info Mode

Overview of Info Mode.....	13
Information Screen	13
Counters Screen	13
Options Screen	13
Editing	14
Cook More.....	14
Load Menu.....	14
VAC.....	14
Demo Mode.....	14
Manual Cooking	14
Diagnostic Mode.....	14
F2 Bypass	14
Settings Screen	15
Temperature Units	15
Language	15
WiFi Network.....	15
Sound Volume	16
Set Date.....	16
Set Time.....	16
Auto On.....	17
Auto Off.....	17
Service Screen	17
Fault Log.....	17
Counters and Timers.....	18
Test Mode.....	18
Manufacturing (MFG).....	19
Oven Model	19
Serial Number	19
Oven Location.....	19
Load Menu from USB	20
Save Menu to USB	20
Firmware Update	21

Edit Mode

Overview of Edit Mode	23
Edit Set Temperature.....	23
Access Edit Items Screen	24
Name a Group.....	24
Delete a Group	24
Move a Group	25

Continued on Next Page...

Edit Mode, Continued...

Item Editing Options.....	26
Edit Settings.....	27
Edit % Time	27
Edit % Air	27
Edit % Microwave.....	28
Edit Cook Time	28
Name an Item	28
Run a Test Cook Cycle	29
Add/Edit Event Messages	29
Name Item.....	30
Change Group	30
Move Item	31
Delete Item	31

Oven Systems

Impingement System	33
Blower Motor	33
Blower Motor Speed Controller (BMSC).....	33
Heater Elements	33
Jetplate	33
Stirrer Motor and Assembly.....	33
Troubleshooting.....	33
Oven Door.....	34
Removing/Reinstalling the Oven Door	34
Adjusting the Oven Door.....	34
Interlock Switches	35
Adjusting the Primary, Secondary, and Monitor Switches.....	35
Measuring RF Leakage for Microwave Safety	36
Troubleshooting.....	36
Microwave System	37
Capacitor.....	37
Testing a Capacitor.....	37
Combination HV/Filament Transformer	37
Wiring the Transformer.....	37
Testing the Transformer	38
High-Voltage Diode	38
Testing the High-Voltage Diode.....	38
Magnetron.....	39
Testing a Magnetron for an Open/Shorted Filament.....	39

Oven Systems, Microwave System, Continued...

Stirrer Motor and Assembly.....	39
Waveguide.....	39
Troubleshooting.....	39
Control System.....	40
Cooling Fan.....	40
Display and UI Control Board (Phoenix).....	40
Electrical Compartment Thermocouple.....	40
EMI Filter.....	40
Fuses.....	40
High Limit Thermostat.....	41
I/O Control Board (Sage).....	41
Magnetron Thermostats.....	41
Power Supply.....	41
Relay Board.....	41
Solid State Relay - K4/K5 Heater.....	41
RTD.....	42
Speaker.....	42
Transformer Thermostats.....	42
USB.....	42
Voltage Sensor.....	42
WiFi Module.....	42
Wire Harness.....	42
Troubleshooting.....	42
Filtering System.....	43
Catalytic Converter.....	43
Air Filter.....	43
Troubleshooting.....	43

Troubleshooting

Overview of Troubleshooting.....	45
Fault Code Descriptions.....	45
Fault Code Troubleshooting.....	47
F1: Blower Running Status Bad.....	47
F2: Cook Temperature Low.....	48
F3: Magnetron Current Low.....	49
F4: Door Monitor Defective.....	50
F5: Magnetron Over Temperature.....	50
F6: Electrical Compartment Temperature High.....	51

Troubleshooting, Continued...

F7: RTD Open	51
F8: Heat Low	52
F9: Cook Cavity Temperature High	52
F10: Communication Failure	53
F12: Firmware Reboot.....	53
F13-1: Cooling Fan Unresponsive.....	54
F13-2: Cooling Fan Not Operating.....	54
Non-Fault Code Troubleshooting.....	55
Cook Door Open	55
No Display - Screen is Blank.....	56
Touch Screen is Locked Up or Unresponsive	57
Oven Keeps Cooling Down, will not Warm Up	58
Menu will not Load.....	59
Firmware will not Update	60
Food Not Cooking Properly.....	61
Speaker Not Beeping After a Cook Cycle.....	62

Oven Schematic

Oven Schematic.....	63
Oven Schematic - I/O Detail	64
Phoenix Display Board Connector Detail	65
Sage Control Board Connector Detail	65
Ladder Diagram - Single Phase	66
Ladder Diagram - Three Phase Delta.....	66
Ladder Diagram - Three Phase Wye	66

Appendix - Oven Components

Replacing Oven Components	A-1
Exterior and Cavity Components.....	A-2
Door Components.....	A-4
Left/Blower Side	A-6
Right/Heater Side and Transformers.....	A-8
Top of Oven and Back Panel.....	A-10
Display Housing	A-12
Power Cords and Wire Harnesses	A-14

This page intentionally blank.

IMPORTANT SAFETY INSTRUCTIONS

⚠ WARNING: When operating this oven, strictly adhere to the following safety precautions to reduce the risk of burns, electric shock, fire, injury, damage to oven or property near oven, or possible exposure to excessive microwave energy.

GENERAL SAFETY INFORMATION

- Read all instructions before using this appliance.
- Read and follow the specific “Precautions to be Observed Before and During Servicing to Avoid Possible Exposure to Excessive Microwave Energy” found on page iii.
- This appliance must be grounded. Connect only to a properly grounded outlet. See “Grounding Instructions” on page ii.
- Install or locate this appliance only in accordance with the provided installation instructions.
- This appliance should be serviced by qualified service personnel only. Contact the nearest authorized service facility for examination, repair, or adjustment.
- Keep the cord away from heated surfaces.
- Liquids, such as water, coffee, or tea are able to be overheated beyond the boiling point without appearing to be boiling. Visible bubbling or boiling when the container is removed from the microwave oven is not always present. **THIS COULD RESULT IN VERY HOT LIQUID SUDDENLY BOILING OVER WHEN THE CONTAINER IS DISTURBED OR A UTENSIL IS INSERTED INTO THE LIQUID.**
- **WARNING:** The contents of feeding bottles and baby food jars must be stirred or shaken and the temperature checked before consumption, in order to avoid burns (IEC 60335-2-90)
- Use this appliance only for its intended uses as described in this manual.
- Only use utensils that are suitable for use in microwave ovens (IEC 60335-2-90)
- **DO NOT** use corrosive chemicals or vapors in this appliance; it is not designed for industrial/laboratory use.
- **WARNING: DO NOT** heat liquids or other foods in sealed containers (e.g., jars, whole eggs, etc.) since they are liable to explode.
- **DO NOT** cook with metal lids or aluminum foil
- **DO NOT** cook without food in the cook cavity.
- **DO NOT** allow children to use this appliance.
- **DO NOT** operate this appliance if it has a damaged cord or plug, is not working properly, or has been damaged or dropped. See “Power Cord Replacement or Removal” found on page ii.
- **DO NOT** cover or block any openings on this appliance.
- **DO NOT** store this appliance outdoors.
- **DO NOT** use this product near water (e.g., near a kitchen sink, in a wet basement, near a swimming pool).
- **DO NOT** immerse the cord or plug in water.
- **DO NOT** let the cord hang over the edge of a table or counter.
- **DO NOT** use a water jet for cleaning. See pages 5-6 in this manual for proper cleaning procedures.
- **WARNING:** Due to the nature of the appliance, the floors around it may be slippery.
- This appliance is not to be used by children or persons with reduced physical, sensory or mental capabilities, or lack of experience and knowledge, unless they have been given supervision or instruction.

SAVE THESE INSTRUCTIONS

REDUCING FIRE RISK

- Remove wire twist-ties from paper or plastic bags used to facilitate cooking in the oven.
- If materials inside the oven ignite, keep the oven door closed, turn the oven off, and disconnect the power cord or shut off power at the fuse or circuit breaker panel.
- If smoke is observed, switch off or unplug the oven. Keep the door closed to stifle any flames.
- DO NOT use the cook cavity for storage purposes.
- DO NOT overcook food. Carefully attend to the oven if paper, plastic, or other combustible materials are placed inside the oven to facilitate cooking.
- DO NOT leave paper products, cooking utensils, or food in the cavity when the oven is not in use.

GROUNDING INSTRUCTIONS

This appliance must be grounded. In the event of an electrical short circuit, grounding reduces the risk of electric shock by providing an escape wire for the electric current. This oven is equipped with a cord that has a grounding wire with a grounding plug, which must be plugged into an outlet that is properly installed and grounded. Consult a qualified electrician or serviceman if uncertain about the ability to follow grounding instructions or if doubt exists as to whether the appliance is properly grounded.

DO NOT use an extension cord. If the power cord is too short, have a qualified electrician or serviceman install an outlet near the appliance.

 **WARNING:** Improper grounding can result in risk of electric shock.

 **WARNING:** Risk of Electric Shock. If the cord or plug becomes damaged, replace only with a cord and plug of the same type

POWER CORD REPLACEMENT OR REMOVAL

If the power cord is damaged, it must be replaced by the manufacturer, its service agent, or a similarly qualified person.

 **WARNING:** If the oven is unplugged during service or maintenance, the user must be able to access and see the plug at all times to ensure that the oven remains unplugged. The plug must remain near the oven and cannot be placed behind another appliance or in another room.

RF INTERFERENCE CONSIDERATIONS

The ECO ST oven generates radio frequency signals. This device has been tested and was determined to be in compliance with applicable portions of FCC part 18 requirements and to the protection requirements of Council Directive 89/336/EEC on the approximation of the laws of the Member States relating to electromagnetic compatibility at the time of manufacture. However, some equipment with sensitivity to signals below these limits may experience interference.

If your equipment experiences interference:

- Increase the physical separation between this oven and the sensitive equipment.
- If the sensitive device can be grounded, do so following accepted grounding practices.
- If battery-powered microphones are being affected, ensure that the batteries are fully charged.
- Keep sensitive equipment on separate electrical circuits if possible.
- Route intercom wires, microphone wires, speaker cables, etc. away from the oven.

SAVE THESE INSTRUCTIONS

PRECAUTIONS TO BE OBSERVED BEFORE AND DURING SERVICING TO AVOID POSSIBLE EXPOSURE TO EXCESSIVE MICROWAVE ENERGY

- (a) DO NOT operate or allow the oven to be operated with the door open.
- (b) Make the following safety checks on all ovens to be serviced before activating the magnetron or other microwave source, and make repairs as necessary: (1) interlock operation, (2) proper door closing, (3) seal and sealing surfaces (arcing, wear, and other damage), (4) damage to or loosening of hinges and latches, (5) evidence of dropping or abuse.
- (c) Before turning on microwave power for any service test or inspection within the microwave generating compartments, check the magnetron, wave guide or transmission line, and cavity for proper alignment, integrity, and connections.
- (d) Any defective or misadjusted components in the interlock, monitor, door seal, and microwave generation and transmission systems shall be repaired, replaced, or adjusted by procedures described in this manual before the oven is released to the owner.
- (e) A microwave leakage check to verify compliance with the Federal Performance Standard should be performed on each oven prior to release to the owner. Refer to page 36 for leakage test procedures.

PROTECTIVE EARTH (GROUND) SYMBOL



This symbol identifies the terminal which is intended for connecting an external conductor for protection against electric shock in case of a fault, or the terminal of a protective earth (ground) electrode.

EQUIPOTENTIAL BONDING SYMBOL



This symbol identifies the terminals which, when connected together, bring the various parts of an equipment or of a system to the same potential, not necessarily being the earth (ground) potential, e.g. for local bonding.

SAVE THESE INSTRUCTIONS

This page intentionally blank.

Specifications and Installation

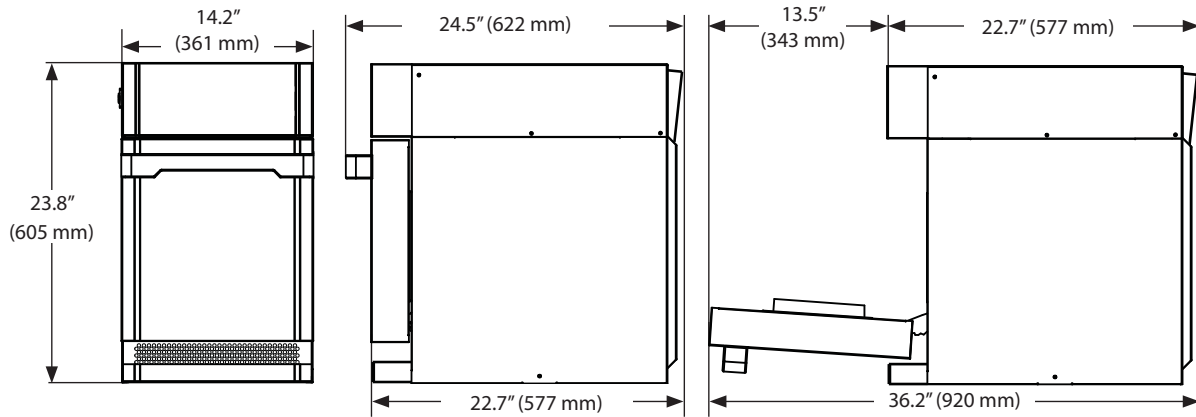

Figure 1: ECO ST Oven Dimensions

Theory of Operation

Utilizing TurboChef's patented technology to rapidly cook food without compromising quality, the ECO ST oven provides superior cooking performance while requiring minimal space and energy consumption. The control system precisely coordinates impinged airflow with top-launched microwave to deliver product-specific results, and integral catalytic converters allow for UL®-certified ventless operation (see page 4 for details).

This manual includes instructions for installing, cleaning, operating, and servicing the ECO ST oven. If you have questions that are not addressed in this manual, contact Customer Support at 800.90TURBO (+1 214.379.6000) or your Authorized Distributor.

Features

- High-contrast, durable capacitive touch screen
- Manual mode for on-the-fly cooking
- Up to 10 selectable languages
- Menu editing tools and USB detection
- WiFi/Middleby Connect™ ready for the connected kitchen

Dimensions

Oven Dimensions

Height: 23.8" (605 mm)
 Width (base): 14.2" (361 mm)
 Depth (footprint): 22.7" (577 mm)
 Depth (door closed): 24.5" (622 mm)
 Depth (door open): 36.2" (920 mm)

Oven Weight

146 lbs. (66 kg)

Cook Cavity Dimensions

Height: 7.2" (183 mm)
 Usable Height: 5.7" (145 mm)
 Width: 12.5" (318 mm)
 Depth: 10.5" (267 mm)
 Usable Depth: 9.3" (236 mm)
 Volume: 0.54 cu ft (15.3 liters)
 Usable Volume: 0.38 cu ft (10.1 liters)

Clearances

Top: 0" (0 mm)
 Sides: 0" (0 mm)

Certifications



cULus, UL EPH, TÜV, CE, FDA

Oven Construction

Exterior

- Corrosion-resistant steel outer wrap and door
- Ergonomic door handle

Interior

- 201/304 stainless steel
- Fully welded and insulated cook chamber
- Removable rack and lower jetplate

Electrical Specifications

TurboChef recommends a Type D circuit breaker for all installations outside the United States.

Single Phase

US/Canada: 208/240* VAC, 60 Hz, 30 A, 6.2 kW
 Europe (UK): 230 VAC, 50 Hz, 27 A, 6.2 kW
 Brazil (BK): 220 VAC, 60 Hz, 28 A, 6.2 kW
 Latin America (LA): 220 VAC, 60 Hz, 28 A, 6.2 kW
 Japan 50 Hz (JK): 200 VAC, 50 Hz, 30 A, 6.2 kW
 Japan 60 Hz (JK): 200 VAC, 60 Hz, 30 A, 6.2 kW

Multi Phase

Europe Delta (ED): 230 VAC, 50 Hz, 20 A, 6.2 kW
 Europe Wye (EW): 400 VAC, 50 Hz, 16 A, 6.2 kW
 Australia Wye (AU): 400 VAC, 50 Hz, 16 A, 6.2 kW
 Japan Delta 50 Hz (JD): 200 VAC, 50 Hz, 20 A, 6.2 kW
 Japan Delta 60 Hz (JD): 200 VAC, 60 Hz, 20 A, 6.2 kW
 Korea/Middle East Wye (KW): 400 VAC, 60 Hz, 16 A, 6.2 kW
 Korea/Middle East Delta (SD): 230 VAC, 60 Hz, 20 A, 6.2 kW

* US/Canada models include a voltage sensor that detects 208 or 240 VAC, but does not compensate for lack-of or over-voltage installations.

Installation

Install or locate this appliance only in accordance with the instructions below.

Unpacking Instructions

1. Remove the oven from its packaging.
2. Before discarding, check the packaging thoroughly for accessories and literature.

NOTE: Packaging may also be retained in case the oven may at some point be shipped somewhere else or returned to the manufacturer.

3. Check the cook cavity thoroughly for accessories and literature.
4. Discard any packaging in the cook cavity.

Installation Warnings - Read Before Lifting Oven

⚠ WARNING: The ECO ST oven weighs approximately 146 lb. (66 kg). TurboChef recommends lifting the oven with no fewer than two people.

⚠ WARNING: Never lift the oven from the front and rear or by the door handle. Doing so will cause the door to misalign, resulting in a non-warranty service call.

⚠ WARNING: The oven must be properly placed on a food station at all times. TurboChef will not recognize a fallen oven as a warrantable claim and is not liable for any injuries that may result.

⚠ WARNING: This oven is not intended for built-in installation (i.e., installing the oven in any structure that surrounds the oven by five or more sides).

⚠ WARNING: This oven is intended to be stacked only with appropriate hardware. Never stack any more than two high.

Lifting and Placing the Oven

1. Prepare a surface at least 22.7" (577 mm) deep and capable of supporting 151 lb. (69 kg).
2. Position one or more persons at the left and right sides of the oven.
3. Place hands under the oven and lift.
4. Place the oven on the prepared surface, ensuring no edges are hanging off the sides.
5. If stacking two ovens:
 - a. See page 1 for dimensions.
 - b. Install the stacking bracket (part number ECS-9420) to the lower oven.
 - c. Place the upper oven on top of the lower oven.
 - d. Secure the bracket to the top oven.
6. Ensure the oven rack is properly installed (attached to the bottom jetplate).
7. Ensure the lower panel (crumb tray) is attached below the oven door.
8. Plug in the oven.

NOTE: The oven is primarily serviced through its top. DO NOT install shelving directly over the unit. The operator will be responsible for service charges incurred as a result of added time required to access the top of the oven.

Installation Near Open Heat Source

When placing a TurboChef oven near an open heat source (Figure 2), strictly adhere to the following:

- If the oven is being placed near a grill or stove, a divider must exist between the oven and the open heat source, with a minimum of 6" (153 mm) between the oven and the divider.
- If the oven is being placed near a fryer, a divider must exist between the oven and fryer, with a minimum of 12" (305 mm) between the oven and the divider.
- The height of the divider must be greater than or equal to the height of the oven, 23.8" (605 mm).

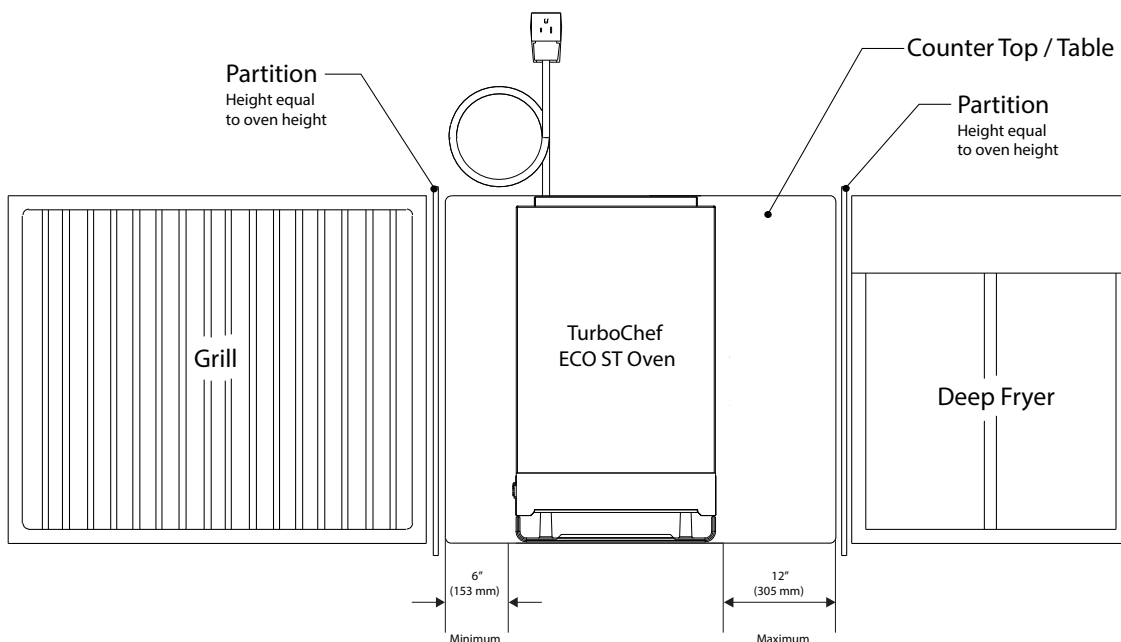

Figure 2: Installation Near Open Heat Source

Oven Restraint Kit

Part Number: [TC3-0242](#)

⚠️ WARNING: The Oven Restraint Kit will not prevent the oven from falling off a countertop if the oven is pulled off or allowed to slide off the edge. Installation instructions are included with the kit.

ChefComm Pro

Part Number: [CON-7006](#)

ChefComm Pro® lets you easily create menu settings on a computer and upload them to an oven via USB. For more information, call TurboChef Customer Support at 800.90TURBO or +1 214.379.6000.

Middleby Connect™

Middleby Connect™ is more than just another piece of WiFi-compatible kitchen equipment. It is a robust enterprise system for developing recipes, updating your oven settings, interpreting oven data, and much more. Middleby Connect™ also enables predictive servicing and maintenance of ovens. It is available for the Double Batch, Single Batch, Bullet, ECO, ECO ST, i1 (Söta, Panini, Waterless Steamer), i3, and i5 ovens with Touch Controls, as well as other Middleby brand equipment.

Date and Time Prompt

The oven maintains a data log that contains valuable information about the operation of the oven, including faults, items cooked, and other events. An accurate date and time are important for the data log. If the oven loses the date and time as a result of prolonged disconnection from power, a prompt will alert the operator to set the date and time. The prompt will only occur once. If bypassed, the operator must update the date and time from the Info Mode Settings screen (see page 14 for details.)

Registration Prompt

At the time the oven is installed, registration information should be input into the oven including store number, address, et cetera. This information is important for warranty tracking purposes. If registration information is not entered, you may be prompted by the oven to input the registration

information whenever the oven is turned on at the start of the day. To eliminate the prompts, simply fill in the registration information requested at the prompt screen.

Voltage Selection

For North America oven models, the oven will detect 208 or 240 incoming voltage.

If incoming voltage for the store is different than the factory-preset voltage, the operator will be required to select either 208 or 240. The correct voltage will be enlarged on the screen, identifying which option to touch (see Figure 3 below).



Figure 3: Selecting Voltage

Ventilation

The TurboChef ECO ST oven has been approved by Underwriter's Laboratory for ventless operation (UL KNLZ listing) for all food items except for foods classified as "fatty raw proteins." Such foods include bone-in, skin-on chicken, raw hamburger meat, raw bacon, raw sausage, steaks, etc. If cooking these types of foods, consult local HVAC codes and authorities to ensure compliance with ventilation requirements.

To ensure continued compliance with all health, building, and fire codes, you are required to maintain clean and sanitary conditions around your oven at all times.

NOTE: In no event shall the manufacturer assume any liability for damages or injuries resulting from installations which are not in compliance with the instructions and codes previously listed. Failure to comply with these instructions could result in the issuance of a temporary cease and desist order from the local health department until the environment concerns are addressed.

Maintenance

Daily Maintenance

Follow the steps below when cleaning your ECO ST oven. Use only TurboChef®-approved cleaning chemicals. The use of any other cleaning products may damage critical oven components, resulting in a non-warranty service call.



Step 1

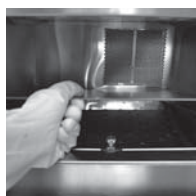

Step 2 (Fig A)

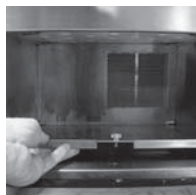

Step 2 (Fig B)



Step 4



Step 5



Step 6

Supplies and Equipment

TurboChef® Oven Cleaner (Product Number: 103180), TurboChef® Oven Guard (Product Number: 103181), Kay ClickSan® sanitizer, nylon scrub pad, cleaning towel, disposable gloves, protective eyewear, dust mask (optional)

Step 1: Prepare the Oven

⚠ WARNING: The oven operates at approximately 500°F (260°C) and may cause injury if not allowed to cool properly.

- Turn off the oven by touching the Off icon.
- Slightly open the oven door.
- Cooling takes approximately 30 minutes. DO NOT proceed to Step 2 until the oven displays “ready to clean.”

Step 2: Remove the Cook Plate and Lower Jetplate

⚠ WARNING: Be sure the oven interior is cool before removing these items.

- Remove the cook plate from the oven (Step 2, Fig. A).
- Loosen the bottom jetplate thumbscrew.
- Lift the front of the bottom jetplate and pull it out from the cavity (Step 2, Fig. B).

Step 3: Clean the Cook Plate and Lower Jetplate

- Wash, rinse, sanitize, and dry the jetplate and cook plate.

Step 4: Remove the Lower Panel and Clean the Air Filter

⚠ CAUTION: TurboChef does not recognize blocked air vents as a warrantable claim. The filter must be cleaned regularly or replaced if damaged. During oven operation, the filter must remain in place at all times.

- Remove the lower panel (under the door) by lifting straight up until the bolts are free from the retaining slots.
- Empty and clean the lower panel.
- Remove the air filter from the front of the oven.
- Rinse the air filter with hot water.
- Allow the air filter to dry completely.

⚠ CAUTION: DO NOT operate the oven without the air filter in place.

Step 5: Wipe the Oven Interior

- Use a food vacuum or damp towel to remove large particles from the oven cavity.

Step 6: Clean the Oven Interior

- Spray TurboChef Oven Cleaner onto the top, bottom, and sides of the interior.

⚠ CAUTION: DO NOT spray Oven Cleaner into the holes on the back oven wall. Doing so can damage critical oven components, resulting in a non-warranty service call.

- Allow Oven Cleaner to penetrate stains for five minutes.
- Clean the oven interior with a nylon scrub pad.

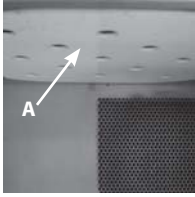

Step 6, Continued

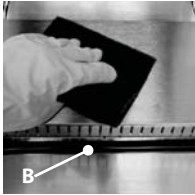

Step 7

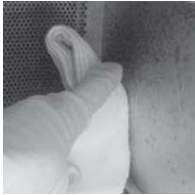

Step 8



Step 9

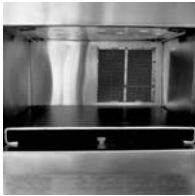

Step 10



Step 11

Step 6: Clean the Oven Interior, Continued

⚠ CAUTION: DO NOT attempt to scrub the upper jetplate (A). If food is stuck to the oven ceiling, gently remove it without applying pressure to the glass plate. Breakage will result in a non-warranty service call.

⚠ CAUTION: DO NOT remove the top glass jetplate (A); breakage will result in a non-warranty service call.

Step 7: Clean and Dry the Oven Door

⚠ CAUTION: DO NOT spray Oven Cleaner directly onto the oven door gasket (B) or saturate it with water.

⚠ CAUTION: DO NOT scrub or attempt to clean the oven door gasket (B). Doing so may cause the oven door to misalign, resulting in a non-warranty service call.

- Clean oven door with Oven Cleaner and a nylon scrub pad.
- Wipe the oven door with a damp towel.

Step 8: Rinse or Wipe the Oven Interior

⚠ CAUTION: DO NOT use a hose or water jet for cleaning. Doing so can damage critical oven components, resulting in a non-warranty service call.

- Wipe down the oven interior with a clean damp towel.
- Dry the oven interior with a clean towel.

Step 9: Apply TurboChef Oven Guard

- Spray TurboChef Oven Guard onto a clean towel.
- Wipe the interior walls and the inside of the oven door.

⚠ CAUTION: DO NOT spray Oven Guard into the cavity, especially around the holes on the back oven wall. Doing so can damage critical oven components, resulting in a non-warranty service call.

Step 10: Reinstall Components

- Reinstall the lower jetplate and tighten the thumbscrew.
- Reinstall the cook plate.
- Close the oven door.
- Reinstall the filter, or replace it with a new one if the mesh is deteriorated, has large openings, or has started to dislodge from the frame.
- Reinstall the lower panel.

Step 11: Clean the Oven Exterior

- Wipe the oven exterior with a clean, damp towel.

⚠ CAUTION: DO NOT spray chemicals into any openings, such as the vents below the door or on the back panel. Doing so can damage critical oven components, resulting in a non-warranty service call.

- The oven is ready to turn on.

Oven Controls and Cooking

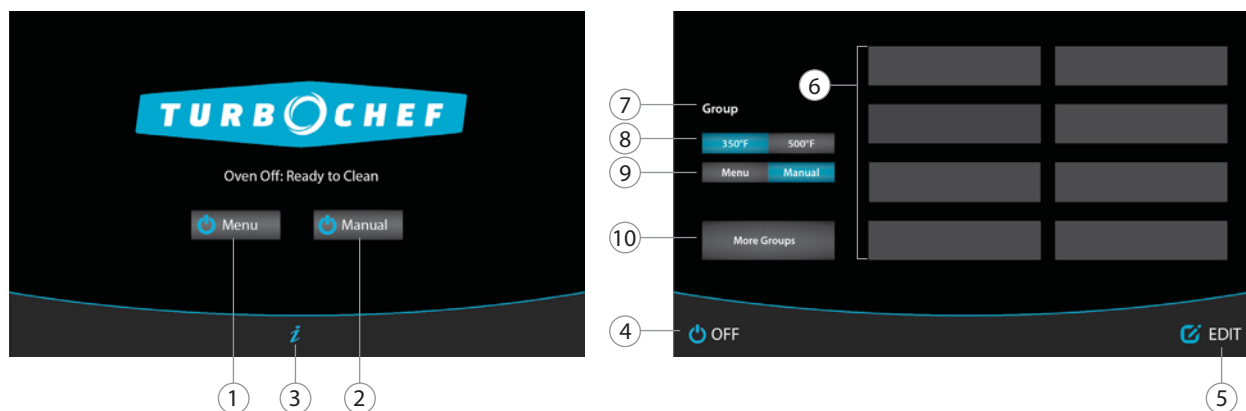

Figure 4: Oven Controls

NOTE: Display options vary depending on which features are enabled.

Oven Controls

1. Menu Icon/Temperature Icon

Touch to turn the oven on and cook in Menu Cook Mode (page 8).

NOTE: If Manual Mode is disabled, a temperature icon will be shown instead of the Menu icon.

2. Manual Icon

Touch to turn the oven on and cook in Manual Cook Mode (page 11). The Manual icon is only present if enabled (page 11).

3. “i” Icon

Touch to access Info Mode (page 13). The “i” icon is only displayed when the oven is off or cooling down.

4. Off Icon

Touch to turn the oven off (cool down).

5. Edit Icon

The Edit icon will only be displayed when Edit Mode (page 23) is enabled. Touching this icon will allow you to edit existing menu items.

6. Groups/Items (1-8 and 9-16)

The oven contains 16 food groups divided into 2 groups of 8. Each food group contains 16 items divided into 2 groups of 8. If applicable, each item contains two quantities.

7. Group Name

When viewing items, the group name indicates which group is being displayed.

8. Set Temperature Toggle

The set temperature toggle will only be displayed when operating with two different set temperatures. Touch the toggle to view groups from the other set temperature.

9. Menu/Manual Toggle

The Menu/Manual toggle will only be displayed when Manual Cooking is enabled, it will allow you to switch between Menu Cook Mode (page 8) and Manual Cook Mode (page 11).

10. More/Previous Groups or Items

This icon will only be displayed when using one set temperature. To view additional groups or items, touch “More Groups” or “More Items.” Or, if on screen two, touch “Previous Groups” or “Previous Items.”

Menu Cook Mode

The oven is preprogrammed with recipe settings at the time of manufacture and is ready to operate out of the box. New menu settings can be loaded via USB (page 20), programmed manually (page 23) or via Middleby Connect™ on page 4.

If settings are not present, the oven will cook only in manual mode (page 11).

This oven uses impingement and microwave to cook food faster than traditional cooking methods. Air enters the cavity from the top and bottom using a single fan. Because of this design and to ensure uniformity of cooking, the oven must be operated only while the bottom jetplate is in place. While the bottom jetplate is removable for cleaning, it is not removable for cooking. Without the bottom jetplate in place, the oven will not deliver the proper cooking performance to either the top or bottom of the food item. Additionally, a non-warranty service call may result.

The sequence of the steps below may vary, and some may not apply.

Step 1: Touch “Menu” or the Oven Set Temperature Icon to Turn the Oven On



Figure 5: Turn the Oven On (Menu or Manual)



Figure 6: Set Oven Temperature

Step 2: Select Cook Temperature



Figure 7: Oven Temperature Display

NOTE: If the temperatures are the same, or if Manual Cook Mode is disabled, this screen will be bypassed.

Step 3: Warming Up



Figure 8: Oven Warming Display

NOTE: When the oven is done warming up, it will “soak” for an additional eight minutes. “Soaking” ensures the cavity surfaces absorb enough heat so that cooking will not be affected.

Step 4: Place Food in the Oven

⚠ WARNING: Inside of oven and oven door are hot!

Step 5: Select a Group



NOTE: Touch “More Groups” to view additional groups.

Figure 9: More Groups - Select a Group

Step 6: Select an Item and, if Applicable, Quantity



NOTE: Touch “More Items” to view additional items.

Figure 10: More Items - More Groups

Step 7: Cooking

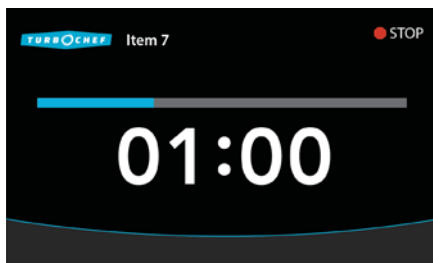

NOTE: To immediately terminate a cook cycle, touch “STOP.”

NOTE: If the oven door is opened during a cook cycle, the cycle will pause until the door is closed. Touch “YES” to resume.

Figure 11: Cook Cycle Time

Step 8: Check/Remove Food from Oven

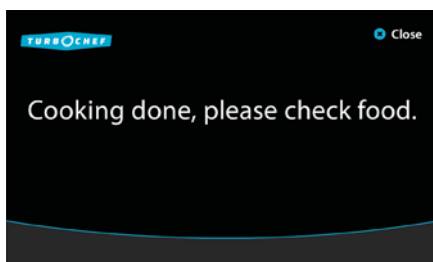

⚠ WARNING: Dish/inside of oven and door are hot!

Figure 12: Cooking Complete

Step 9: Cook More / Brown More / Cook & Brown More



Figure 13: More Items

NOTE: This option must be enabled in order to cook an item beyond its original cook time (see page 14 for details).

To cook an item longer than its original cook time, touch one of the icons on the screen:

- Touch “Cook More” if the inside of the food item requires cooking.
- Touch “Brown More” if the outside of the food item requires browning or crisping.
- Touch “Cook & Brown More” if both the inside and outside of the food item require cooking.

Selecting one of these options will cook the item for 20% of the last cook time selected. The minimum cook time is the fewer of 15 seconds or the entire original cook cycle. The maximum cook time is one minute. The oven will cook at the settings listed below:

- Cook More: 10% air, 100% microwave
- Brown More: 100% air, 0% microwave
- Cook & Brown More: 100% air, 100% microwave

Step 10: Cooling Down



Figure 14: Oven Cooling

When finished cooking for the day, touch “OFF” to turn the oven off and begin cooling down.

Manual Cook Mode

Manual Cook Mode allows cooking “on the fly,” whereas Menu Cook Mode (page 8) allows cooking from preset cook settings. To access Manual Cook Mode, touch the Manual icon when the oven is off or cooling down (page 10) or touch the Menu/Manual toggle on the Menu Mode screen.

NOTE: If the “Manual” icon is not present, enable it from the Options Screen (page 13).

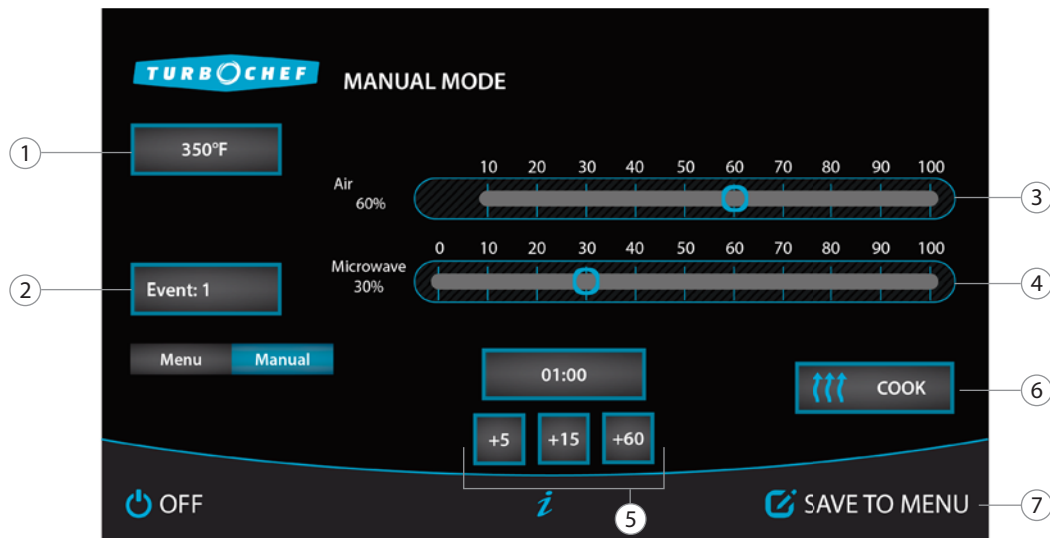

Figure 15: Manual Cook Controls

1. Set Temperature

Touch to change the set temperature. The temperature range is 350–525°F (177–274°C).

2. Events

Manual mode can store six unique cook settings, called events. Touch “Events” to view settings for events 1 through 6.

3. % Air

% Air determines the amount of airflow. The more air, the more the product will brown or crisp. % Air can be set from 10%–100% in 10% increments.

4. % Microwave

% Microwave determines the amount of microwave, and can be set from 0-100% in 10% increments. For example, 50% means the microwave system will remain on for five continuous seconds for every ten seconds during the cook cycle.

5. Time

Time can be set from 0-60 minutes. There are four time icons. The first allows the operator to enter the time manually. The others allow the operator to add time in 5, 15, or 60 second increments.

6. Cook

Touch to cook.

NOTE: The oven may require additional warming time before cooking is allowed.

7. Save to Menu

If you want to save a manual mode setting into the oven menu, touch “Save to Menu.” All six events will be added together as one menu recipe item, and the cook times for each event will be summed and divided into percentages of one cook cycle.

Continued on next page...

7. Save to Menu, continued

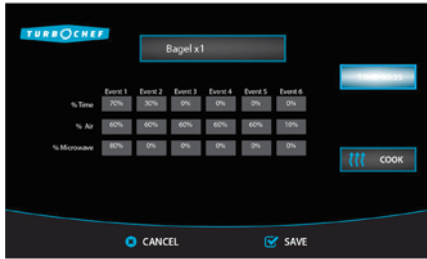

Figure 16: Edit Menu Settings Screen

- a. Edit settings, if necessary, by touching the setting you wish to edit. From this screen, the following settings are editable:
 - % Time
 - % Air
 - % Microwave
 - Time
 - Recipe Name

NOTE: For additional editing instructions, see page 27.

- b. Touch “SAVE.”

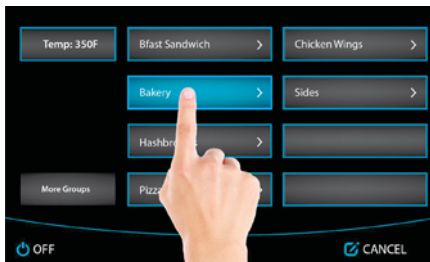

Figure 17: Items Screen

- c. Select a group into which the new menu item will be added.
- d. Select an item to determine the position of the new recipe.

NOTE: If a recipe already existed in the position selected, it will be overwritten.

Info Mode

Overview of Info Mode

To access Info Mode, touch the “i” icon when the oven is off, cooling down, or in manual mode. From the Info Mode screen, access:

- Information
- Counters
- Options
- Settings
- Service
- Manufacturing (MFG)

Information Screen



Figure 18: Information Screen

From the Information screen, view

- Serial Number
- Menu Version (touch to Edit)
- Sage Firmware
- Phoenix Firmware
- Service Number
- VAC (Voltage) - View Incoming Voltage (North America only)
- WiFi Connectivity Status
- WiFi Reset: Reboot the WiFi module to help troubleshoot connectivity issues.
- Tutorials: View information on installing, operating, and maintaining the oven.

Counters Screen



Figure 19: Counters Screen

From the Counters screen, view

- Cook counter
- Total cook time
- Magnetron time
- Total time (oven on)
- Power Cycle Count: The number of times the oven has cycled power.
- Menu Repair Counter
- Fault log: View time stamps of each fault occurrence and the fault code.

Options Screen

From the Information Screen, touch “Login” to access the Options screen. When prompted, input the password 9 4 2 8 and then touch “ENTER.”



Figure 20: Options Screen

From the Options screen, enable/disable

- Editing
- Cook More
- Load Menu
- VAC
- Demo Mode
- Manual Cooking
- Diagnostic Mode
- F2 Bypass

Editing

Edit Mode shows or hides the button that allows the operator to change menu settings, rename food groups and items, and change the cooking temperature. The Edit icon will be displayed at the bottom of the screen (page 7) when this option is set to YES. See page 27 for more details on editing menu settings.

Cook More

Cook More controls whether or not the three “cook more” options appear when a cook cycle is done. This option must be enabled in order to cook an item beyond its original cook time. See page 10 for details.

Load Menu

Load Menu enables or disables downloading new menu settings from USB.

VAC

When VAC is set to YES the selected incoming voltage will be displayed on the Info screen. This is set by the factory and should not be changed, and applies only within North America.

Demo Mode

Demo Mode is a feature used to demonstrate the cooking features of the oven without turning on the heaters or microwave system. Demo Mode must be set to NO during regular operation.

Manual Cooking

When Manual Cooking is set to YES, the operator can cook items “on the fly.” See page 11 for more details.

Diagnostic Mode

Diagnostic Mode allows the operator to view and test oven components. This mode should only be used by qualified service technicians, unless otherwise instructed by TurboChef. When Diagnostic Mode is turned on, the oven will show the following information during cooking:

- Event currently being cooked
- % wave and % air
- Status indicators (see page 18)
- Cavity temperature
- CC set point
- Electrical compartment temperature

To turn Diagnostic Mode on or off, press the key adjacent to “Diagnostic.” For normal oven operation, Diagnostic Mode should remain off.

F2 Bypass

The F2 alarm indicates the oven temperature is too low. YES means the oven will not terminate a cook cycle when an F2 alarm is encountered so the food product can finish cooking. The oven will still log the fault condition. NO means the oven will function as it normally would; i.e., when an F2 alarm is discovered during a cook cycle, the oven will terminate the cook cycle. See page 45 for more information.

Settings Screen

From the Information or Counters screen, touch “Login” to access the Settings screen. When prompted, input the password 9 4 2 8 and then touch “ENTER.”

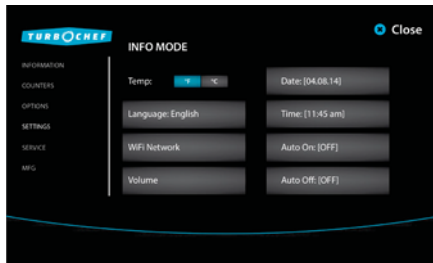

Figure 21: Settings Screen

From the settings screen, set

- Temperature Units
- Language
- WiFi Network
- Sound Volume
- Date
- Time
- Auto On
- Auto Off

Temperature Units

The temperature unit setting is configured at the factory. Touch °F (Fahrenheit) or °C (Celsius) to change the temperature units.

Language

The default language is English. To change to another language, touch “Language: English” and then touch the preferred language and touch “ENTER.” Available languages may include:

- French
- German
- Polish
- Portuguese
- Spanish
- Chinese
- Korean
- Japanese
- Russian
- Dutch

WiFi Network

NOTE: Feature or service may not be available, and must be requested at the time of oven order.

Connecting the oven to a WiFi network and utilizing TurboChef’s connectivity services, such as Middleby Connect™ (page 4) will allow you to remotely update the menu and firmware for one or all of your ovens. It will also enable access to reporting tools and live data streams to view what is being cooked and when.

Special configurations may apply. Contact your facility administrator for more information.



Figure 22: WiFi Network Screen

From the WiFi Network setup screen (above), the following information may be entered to configure the oven for networking:

- WiFi On/Off
- SSID
- Security Type
- WiFi Password

1. WiFi On/Off

Toggle this option to enable/disable the oven’s WiFi capabilities.

2. SSID

The SSID is the case sensitive name of the WiFi network that you wish the oven to join. After touching the SSID icon, use the on-screen keyboard to either select from a list of broadcast SSIDs, or type in the WiFi network name and touch Enter.

If you are unsure of the SSID for the network, contact your network administrator.

Continued on next page...

3. Security Type

Ensure the security type is set to WPA2 unless otherwise instructed by your network administrator.

4. WiFi Password

The WiFi Password is the case sensitive password needed to join the WiFi network. After touching the WiFi Password icon, use the on-screen keyboard to type in the WiFi network password and touch Enter.

If you are unsure of the WiFi Password for the network, contact your network administrator. In some instances, the WiFi Password may be printed on a label on the bottom of your WiFi router.

NOTE: “Open” or public networks may require additional authentication. Contact TurboChef customer support at 800.90TURBO or +1 214.379.6000 for assistance. Coordination with a network administrator may be required.

5. Channel

The Channel is determined and assigned by the WiFi router.

NOTE: If you are experiencing difficulty obtaining or keeping WiFi connectivity, TurboChef recommends setting the WiFi router’s channel to 1.

Change the network channel by logging into your router. For help with your WiFi router, contact your network administrator.

6. MAC IP

The MAC IP is automatically assigned.

7. SAVE Button

After entering or updating any of the settings on the WiFi Network screen, touch the SAVE button.

Touching the SAVE button will cause the oven to attempt to connect to the network.

Ensuring Connectivity

When the oven is successfully connected to a network, the Information screen will indicate the oven is “connected.” See page 13.

If MAC IP is blank, the oven may not be configured properly to connect to a WiFi network. Call TurboChef Customer Support at 800.90TURBO or +1 214.379.6000.

Sound Volume

Touch “Volume” and use the plus or minus icons or slider to increase or decrease the beep volume.

Set Date

To set or correct the date, touch “Date.” Enter the date in the following format - MM/DD/YY. Touch “ENTER” to save the changes.

Set Time

To set the time, touch “Time.” Enter the time in 24-hour format (8:30 p.m. = 20:30). Touch “ENTER” to save the changes.

NOTE: The clock will not automatically update for Daylight Savings Time.

NOTE: The user interface will automatically convert the time to 12-hour format.

Auto On

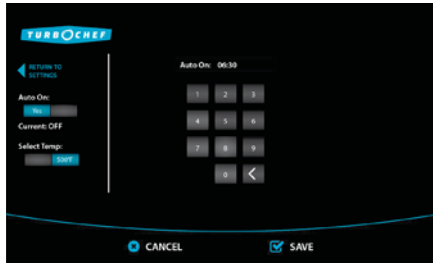

Figure 23: Oven Status (Auto On) Screen

“Auto On” is a feature that turns the oven on automatically at a specific time of day.

1. To set auto-on, ensure the time of day is accurate (above).
2. Toggle the yes/no icon to the YES position to enable Auto On.
3. Select the temperature to which the oven will automatically heat up.
4. Enter the time in 24-hour format (20:30 = 8:30 p.m.). Touch “SAVE” to save all changes.

NOTE: The time will automatically convert to 12-hour format when saved.

Auto Off

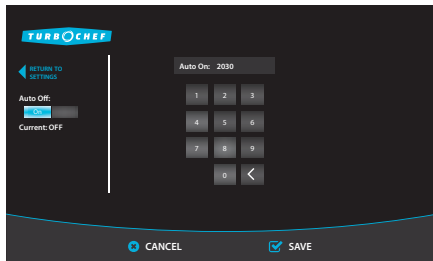

Figure 24: Oven Status (Auto Off) Screen

“Auto Off” is a feature that turns the oven off automatically at a specific time of day.

1. To set auto-off time, ensure the time of day is accurate.
2. Toggle the yes/no icon to the YES position to enable Auto Off.
3. Enter the time in 24-hour format (20:30 = 8:30 p.m.). Touch “SAVE” to save all changes.

NOTE: The time will automatically convert to 12-hour format when saved.

Service Screen

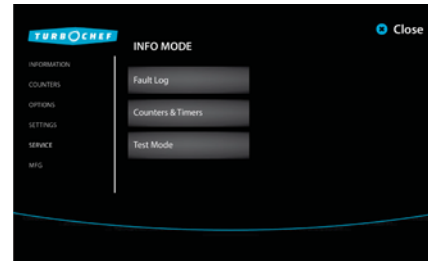

Figure 25: Service Screen

From the Service screen, view:

- Fault Log
- Counters and Timers
- Test Mode

Fault Log

View the faults by Count or History. Use the toggle to change between count view and history view.

Faults by Count

Shows the number of faults occurred by fault code. Press “Reset” to reset all counters to 0 and press the down arrow to view the rest of the fault codes.

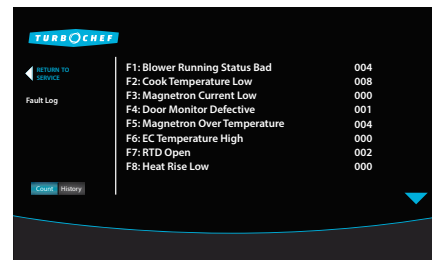

Figure 26: Faults by Count Screen

Faults by History

View time stamps of each fault occurrence and the fault code.

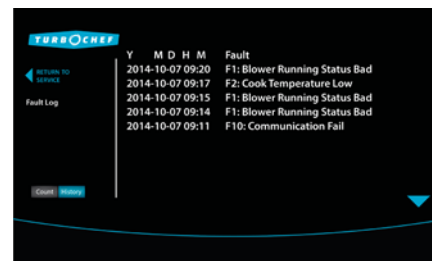

Figure 27: Faults by History Screen

NOTE: If the fault counts are all “0,” exit the Info Mode and re-enter it to refresh the screen.

Counters and Timers

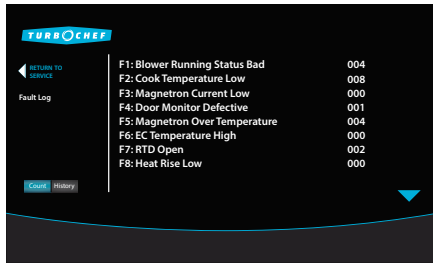

Figure 28: Fault Log Counters Screen

From the Counters screen, view:

- Cook Counter
- Total Cook Time
- Magnetron Time
- Total Time (oven on)
- Power Cycle Count: The number of times the oven has cycled power.
- Fault log: View time stamps of each fault occurrence and the fault code

Test Mode

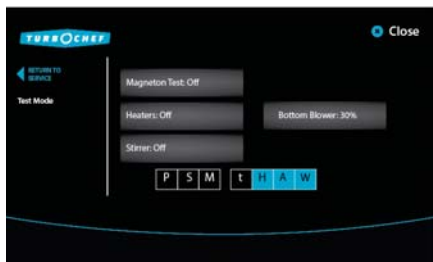

Figure 29: Test Mode Screen

Test Mode allows the service technician to test individual components to verify operation. From Test Mode, perform the following:

- View Status Indicators
- Magnetron Test
- Heater Control
- Control Blower Speed
- Stirrer Control

View Status Indicators

- P = Primary switch (backlit = open)
- S = Secondary switch (backlit = open)
- M = Monitor switch (backlit = open)
- t = Magnetron thermostat (backlit = open)
- H = Heater (backlit = off)
- A = Blower Motor (backlit = off)
- W = Microwave (backlit = off)

Magnetron Test

To turn on the magnetrons, touch and hold the “Magnetron Test” icon. To turn them off, release the icon. While holding the “Magnetron Test” icon, measure the current transformer wire on the control board for 13-15A (240 V) or 15-17A (208 V).

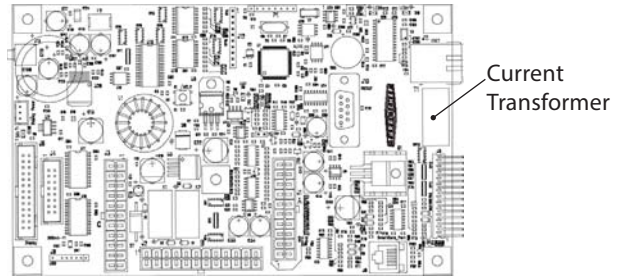

Figure 30: Sage Control Board, Current Transformer

For more information on magnetron-related issues:

- See page 39 for additional testing options.
- See page 49 for F3 troubleshooting.
- See page 50 for F5 troubleshooting.

Heater Control

To turn on the heater (H), touch the “Heaters: Off” icon. To turn it off, touch the icon again. The icon will display on or off, depending on the status of the heater.

While the heater is on, the backlight behind the “H” status indicator at the bottom of the screen should turn off. This means the heater is on. If the heater is not heating up while the icon indicates that it should be, see pages 48 and 52 for troubleshooting.

Control Blower Speed

Touch the “Blower” icon to increase the blower motor speed of the blower in 10% increments.

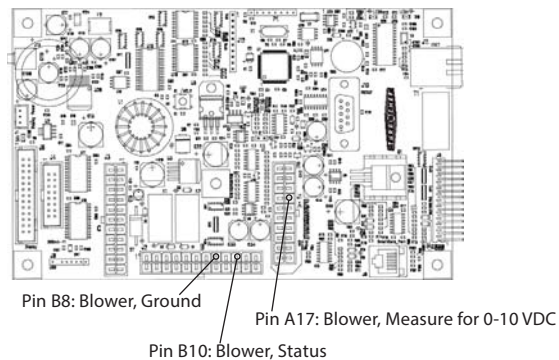

Figure 31: Sage Control Board, Blower Test Points

Test for voltage on the BMSC J1 connector:

1. Ground pin 5 of the J1 connector.
2. While pin 5 is grounded, check the terminals on the control wiring plug for 0-10 VDC across pins 1 and 2 of the J1 connector while increasing the blower speed. The measurement should increase appx. 1 VDC for each 10% increase in blower speed, up to 100% (10 VDC), which is approximately 7,000 RPM.

Stirrer Control

Press the “Stirrer: Off” icon to turn on the stirrer motor. To turn it off, touch the icon again. The icon will display on or off, depending on the status of the stirrer.

Manufacturing (MFG)

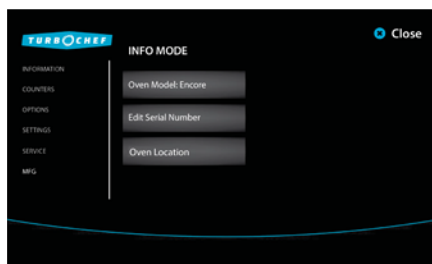

Figure 32: Manufacturing (MFG) Screen

From the MFG screen, change:

- Oven Model
- Serial Number
- Oven Location

Oven Model

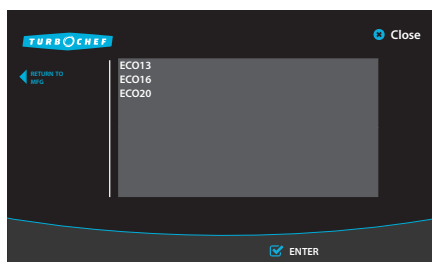

Figure 33: Oven Model

The oven model shown on the screen is pre-set at the factory and must match the model of the oven being serviced. If this setting must be changed, select the proper oven model from the list shown on the display.

⚠ CAUTION: An improperly set oven model will result in the oven not cooking properly.

Serial Number



Figure 34: Serial Number Screen

If necessary, edit the serial number using the on-screen keyboard.

Oven Location

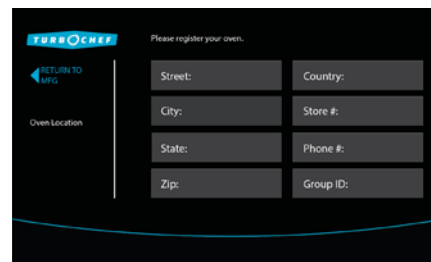

Figure 35: Oven Location Screen

If necessary, edit the oven location using the on-screen keyboard.

Load Menu from USB

NOTE: To update a menu, you may need to verify that access to the Load Menu screen is turned on. See page 14 for details.

USB Setup: When loading from USB, the menu must be in BIN (binary) format. The files must be loaded on the root of the USB. To obtain the proper binary file, contact your menu administrator, TurboChef Technical Support, or consult your ChefComm Pro® instructions.

To load a menu to the oven,

1. When the oven is off or cooling down, insert the USB. The oven will automatically detect the device. Touch “OK” to proceed.

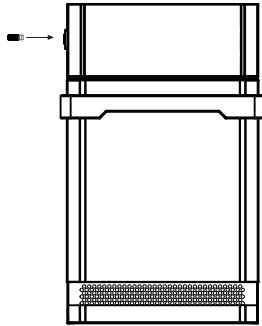

2. Load the menu:
 - a. Touch “Load Menu to Oven.”



Figure 36: USB Screen - Load Menu to Oven

- b. Touch “OK” to confirm the selection and begin the installation.

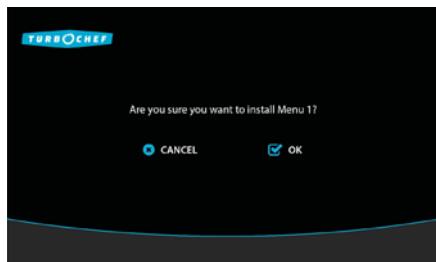

Figure 37: Load Menu to Oven Confirmation Screen

- c. If multiple menus are on the USB, the oven will display the menu names. Touch the menu to load. If only one menu file is on the USB, this step will be bypassed.
 3. Once installation is complete, the oven will display “Installation Complete.” Remove the USB and return the oven to service.

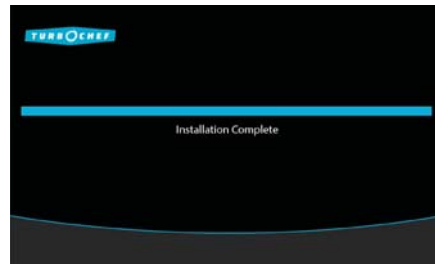
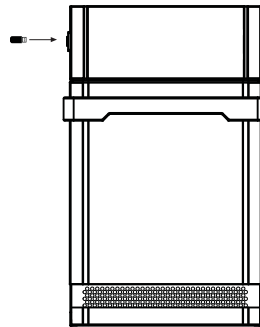

Figure 38: Installation Complete

Save Menu to USB

If desired, name the menu from the Menu Info screen to make it easy to find on your USB drive. See page 14.

1. When the oven is off or cooling down, insert the USB. The oven will automatically detect the device. Touch “OK” to proceed.



2. Touch “Save Menu to USB.”



Figure 39: USB Screen - Save Menu to USB

3. Touch “OK” to save the menu to the USB.
Touch “CANCEL” to go back to the previous screen.



Figure 40: Save Menu Confirmation Screen

4. Once installation is complete, the oven will display “Save Complete.”

NOTE: The menu file will be saved in the root directory on the USB.

Firmware Update

TurboChef may at some point recommend a firmware update. The update will make sure your oven is operating at its maximum efficiency, but should not affect cooking results or menu settings.

⚠ CAUTION: Do not remove the USB until “Installation Complete” is displayed.

1. When the oven is off or cooling down, insert the USB. The oven will automatically detect the USB. Touch “OK” to proceed.

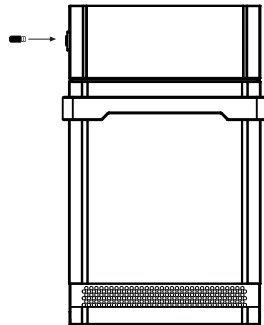

2. Load the firmware:
 - a. Touch “Update Firmware.”



Figure 41: USB Screen - Update Firmware

- b. Touch “OK” to confirm the selection.



Figure 42: Update Firmware Confirmation Screen

3. The oven will install each firmware file included with the update. Once installation is complete, the oven will display “Installation Complete.”

This page intentionally blank.

Edit Mode

Overview of Edit Mode

To enable Edit Mode,

1. Touch the “i” icon when the oven is off or cooling down.
2. From the Info Mode screen, touch “Login” to access the Options screen. When prompted, enter the passcode 9 4 2 8 and then touch “Enter.”
3. Set “Editing” to “YES” to enable Edit Mode.

The “Edit” icon will appear at the bottom of the screen in Menu Cook Mode (see page 7). When “Edit” is touched from the Group select screen, the operator can:

- Edit the set temperature
- Access the edit items screen
- Name a group
- Delete a group
- Move a group

When “Edit” is touched from the Item select screen, the operator can:

- Edit item cook settings
- Name an item
- Add a recipe from the cookbook
- Change group
- Move item
- Delete item

Edit Set Temperature

The menu set temperature should never be changed to compensate for over-cooking or under-cooking. If recipe settings are not cooking as desired, consult your menu developer, authorized distributor, or TurboChef Customer Support.

To change a set temperature:

1. Place the oven in Edit Mode.



Figure 43: Edit Mode Screen

2. Touch the current set temperature.

NOTE: The set temperature will apply only to the groups adjacent to it. Be sure to check the temperature for groups 1-8, but also for groups 9-16.

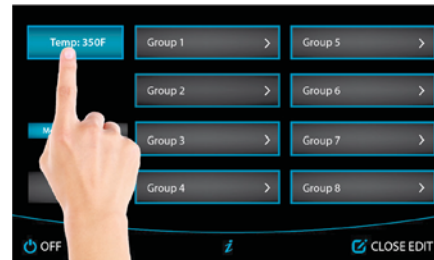

Figure 44: Set Temperature Screen

3. Using the number keys, enter the new set temperature. The temperature range is 350-525°F (177-274°C).

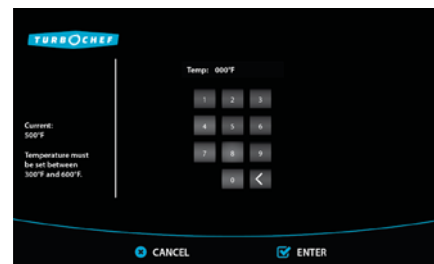

Figure 45: Enter Temperature Screen

4. Touch “ENTER” to confirm the change.

Access Edit Items Screen

Item settings can be edited from the Edit Settings screen. See page 27 for more details.

Name a Group

To name or edit a group name:

1. Place the oven in Edit Mode.

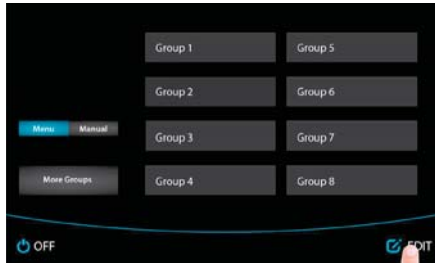

Figure 46: Edit Mode Screen

2. Select a Group.



Figure 47: Select a Group Screen

3. Touch “Name Group.”

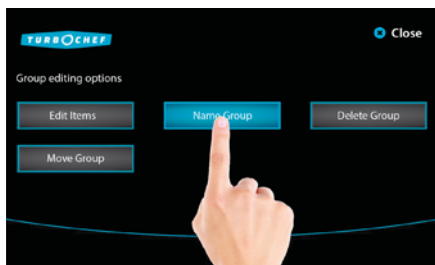

Figure 48: Group Editing Options Screen - Name a Group

4. Using the keypad, enter the new group name. Touch “ENTER” to save changes.



Figure 49: Enter a Group Name Screen

NOTE: Touch the “123” icon to access numbers and symbols.

NOTE: Touch the  icon to change case between upper and lower case.

NOTE: Touch the Alt icon to show special characters.

Delete a Group

To delete a group:

1. Place the oven in Edit Mode.



Figure 50: Edit Mode Screen

2. Touch the group to delete.



Figure 51: Select a Group Screen

3. Select "Delete Group."

NOTE: Deleting a group will delete all items in the group.

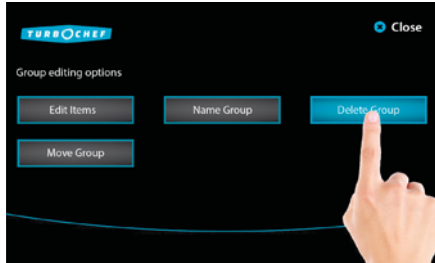

Figure 52: Group Editing Options Screen - Delete a Group

Move a Group

To move a group to another location:

1. Place the oven in Edit Mode.

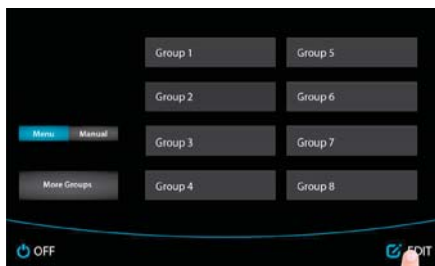

Figure 53: Edit Mode Screen

2. Touch the Group to move.



Figure 54: Select a Group Screen

3. Touch "Move Group."

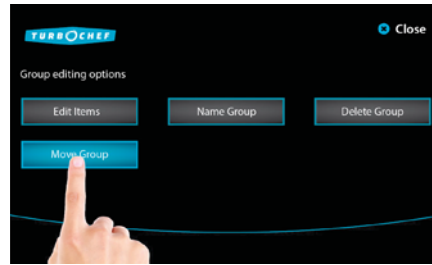

Figure 55: Group Editing Options Screen - Move a Group

4. The group to be moved will be highlighted blue.

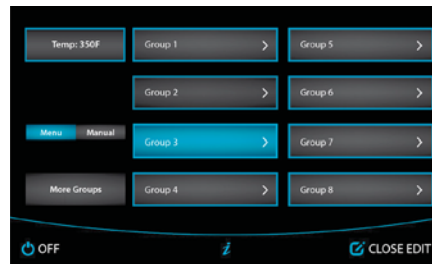

Figure 56: Move a Group Screen - Group to Move

5. Touch the new location for the group.

NOTE: If a group is moved to a space that already contains settings, the old settings in that space will be overwritten.

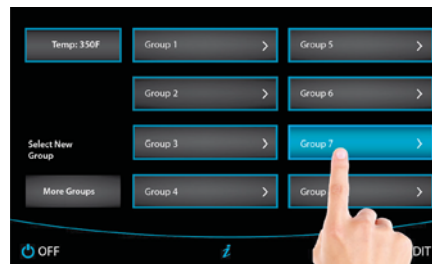

Figure 57: Move a Group Screen - Move Group

Item Editing Options

To access the Edit Settings screen:

1. Touch “EDIT” to place the oven in Edit Mode.

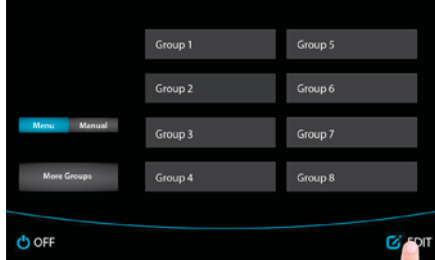

Figure 58: Edit Mode Screen

2. Touch the group that contains the item to edit.

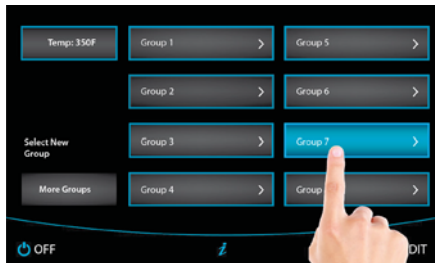

Figure 59: Select a Group Screen

3. Select “Edit Items.”

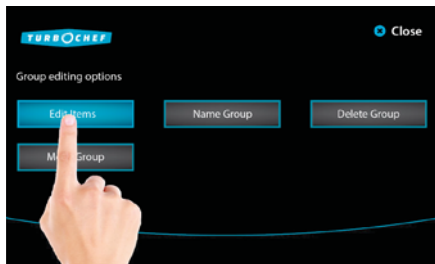

Figure 60: Group Editing Options Screen - Edit Item

4. Touch an item to edit.



Figure 61: Select Item Screen

5. From the Item Editing Options screen, the operator can:

- Edit Settings
- Name an Item
- Change the Group
- Move an Item
- Delete an Item

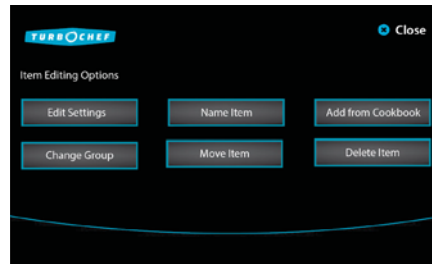

Figure 62: Item Editing Options Screen

Edit Settings

From the Item Editing Options screen (page 26), select “Edit Settings.” From the Edit Settings screen the operator can:

- Edit % Time
- Edit % Air
- Edit % Microwave
- Edit Cook Time
- Name an Item
- Run a Test Cook Cycle
- Add/Edit Event Messages (feature available on request)

Edit % Time

Touch a % Time icon to change, enter the new percentage, and touch “ENTER.” % Time can be set from 0-100% for each event. The sum of all events must be 100. Once all changes are made, touch “SAVE.”

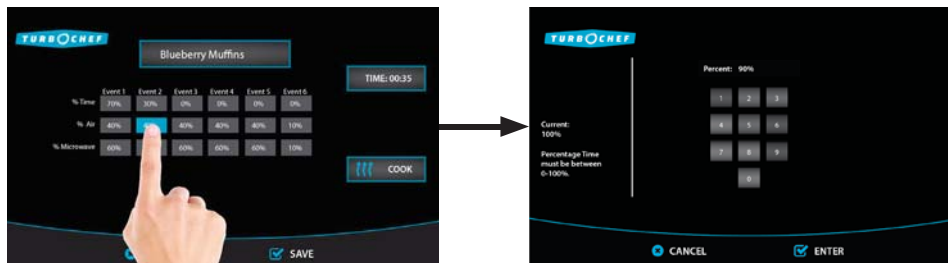

Figure 63: Edit % Time

Edit % Air

Touch the % Air to change and adjust it using the sliding bar that appears below the grid. % Air determines the amount of airflow. The more air, the more the product will brown or crisp. % Air can be set from 10-100% in 10% increments. Once all changes are made, touch “SAVE.”

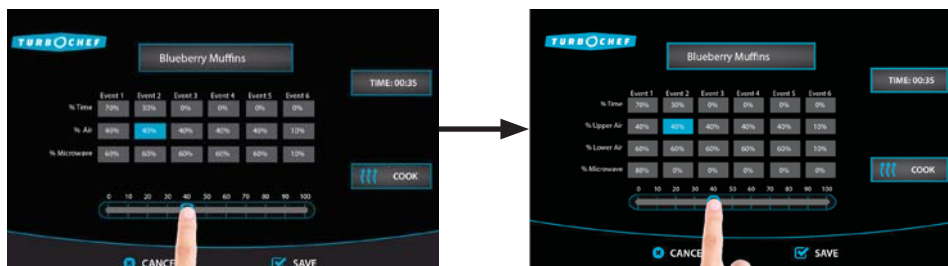

Figure 64: Edit % Air

Edit % Microwave

Touch the % Microwave to change and adjust it using the sliding bar that appears below the grid. % Microwave can be set from 0-100% in 10% increments. For example, 50% means the microwave system will remain on for five continuous seconds for every ten seconds during the cook cycle. Once all changes are made, touch “SAVE.”

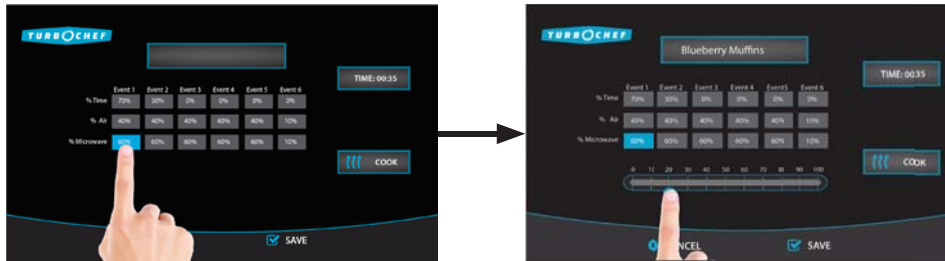

Figure 65: Edit % Microwave Screen

Edit Cook Time

Touch the current cook time. The maximum allowable cook time is 60 minutes. Using the number keypad, enter the cook time and touch “ENTER.” Once all changes are made, touch “SAVE.”

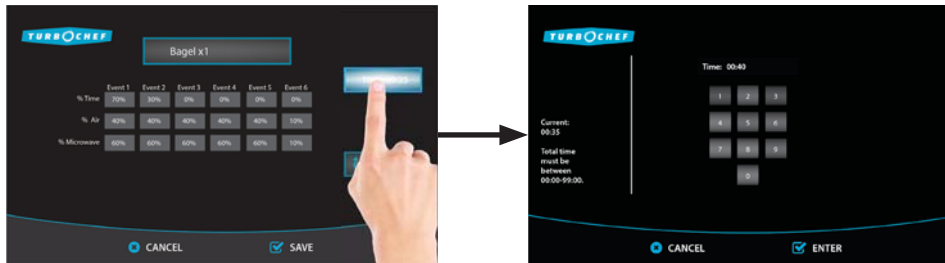

Figure 66: Edit Cook Time Screen

Name an Item

Touch the current name or the button that reads “Name”. Using the keypad, input the name and touch “ENTER.” Once all changes are made, touch “SAVE.”

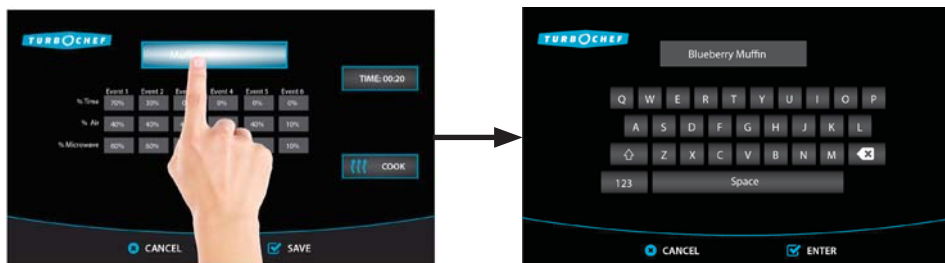

Figure 67: Name an Item Screen

NOTE: The field allows for a maximum of 16 characters.

NOTE: Touch the “123” icon to access numbers and symbols.

NOTE: Touch the  icon to change case between upper and lower case.

NOTE: Touch the Alt icon to show special characters.

Run a Test Cook Cycle

If desired, touch “Cook” to perform a test cook.

NOTE: The oven may require additional warm-up time before a test cook can be performed.



Figure 68: Run a Test Cook Cycle Screen

Add/Edit Event Messages

Event messages are alerts that pause a cook cycle and show a message. When cooking, the message will appear immediately before the event to which the message was applied. For example, a message applied to event 1 will appear before the cook cycle begins. Event messages must be specified at the time of manufacture.

When event messages are specified, the Edit Item Screen is modified as shown in figure 69.

Touch the icon beneath the cook settings for the event you want to add a message to and, using the keypad, input the name and touch “Enter.” Once all changes are made, touch “SAVE.”

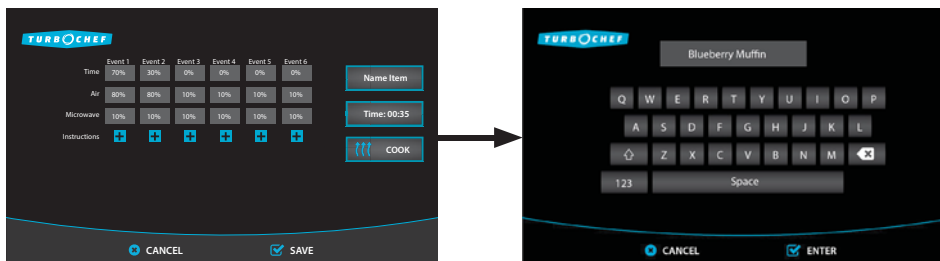

Figure 69: Item Edit, Event Messages

NOTE: The field allows for a maximum of 32 characters.

NOTE: Touch the “123” icon to access numbers and symbols.

NOTE: Touch the  icon to change case between upper and lower case.

NOTE: Touch the Alt icon to show special characters.

Name Item

From the Item Editing Options screen (page 26), select “Name Item” to name or edit an item name. After editing the name, touch “ENTER” to save changes.

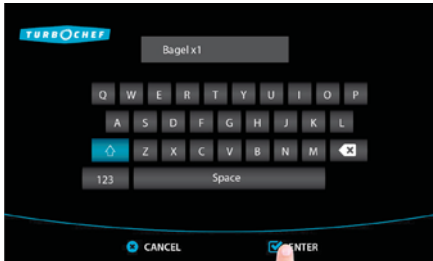

Figure 70: Name an Item Screen

NOTE: The field allows for a maximum of 16 characters including spaces.

NOTE: Touch the “123” icon to access numbers and symbols.

NOTE: Touch the ↕ icon to change case between upper and lower case.

NOTE: Touch the Alt icon to show special characters.

Change Group

1. From the Item Editing Options screen (page 26), select “Change Group.”
2. Select a new group.
3. Touch an item space to indicate where the item will be moved.

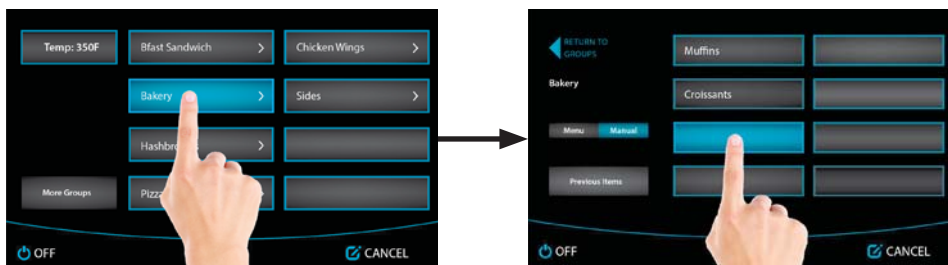

Figure 71: Change a Group Screen

NOTE: If an item is moved to a space that already contains settings, the old settings will be overwritten.

Move Item

1. From the Item Editing Options screen (page 26), select “Move Item.” The item to be moved will be highlighted blue.
2. Touch an item space to indicate where the item will be moved.

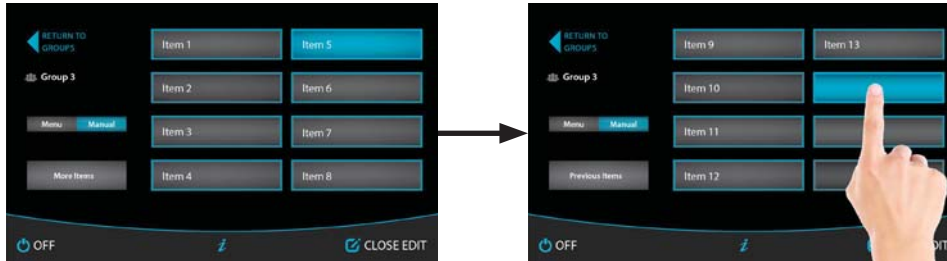

Figure 72: Move an Item Screen

NOTE: If an item is moved to a space that already contains settings, the old settings will be overwritten.

Delete Item

From the Item Editing Options screen (page 26), select “Delete Item.” Touch “OK” to delete the item.

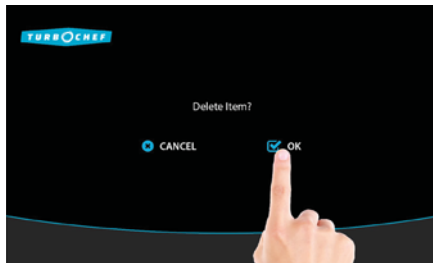

Figure 73: Delete an Item Screen

NOTE: Once an item is deleted, it cannot be recovered.

This page intentionally blank.

Oven Systems

Impingement System

The impingement system is designed to rapidly heat, clean, and recirculate air into the cook cavity.

This section contains information about the following components:

- Blower motor
- Blower motor speed controller (BMSC)
- Heater elements
- Jetplate
- Stirrer motor and assembly

For information on accessing and removing parts, see the Appendix.

Blower Motor

The blower motor is a brushless AC-switch reluctance type and spins counter clockwise. Its top speed is 7100 RPM at 1 HP, and it is controlled by a proprietary controller.

The blower motor can be tested in Test Mode (see page 18).

Blower Motor Speed Controller (BMSC)

The motor controller is proprietary and will only operate the motor described above. It is controlled via (0-9.5) VDC speed command from the Sage control board and can be tested in Test Mode by testing the blower motor. For additional troubleshooting, see page 47.

Heater Elements

The heaters are sheathed-style and rated at 2250 watts at 208 VAC, with a resistance of 14.4 Ohms. The heaters are controlled by the K4/K5 solid state relay, and can be tested in Test Mode (see 18).

Jetplate

The bottom and top jetplates channel air generated from the blower motor into the cook cavity.

 **CAUTION:** The top jetplate is ceramic. Be careful when removing or reinstalling it.

Stirrer Motor and Assembly

The stirrer is responsible for evenly distributing hot air and microwave that enters the cook cavity from the top. The stirrer is driven by a motor that remains on during a cook cycle or when the oven is in Test Mode. The stirrer motor turns off when the oven is not cooking.

The stirrer motor can be tested in Test Mode (see page 18).

Troubleshooting

The following faults may occur in relation to the convection system:

- F1: Blower (see page 47)
- F2: Low Temp (see page 48)
- F7: Thermo (see page 51)
- F8: Heat Low (see page 52)
- F9: Cook Cavity Over Temp (see page 52)

The following cooking performance issues may occur in relation to the convection system:

- Food not cooking properly (see page 61).

Oven Door

This section contains information about the following components:

- Oven door
- Interlock switches

This section also contains procedures for:

- Removing/reinstalling the oven door
- Adjusting the oven door
- Adjusting the primary, secondary, and monitor switches
- Measuring RF leakage for microwave safety

For information on accessing and removing parts, see the Appendix.

The oven door assembly consists of a shunt plate, skin, handle, and hinges. Each of these items can be serviced and replaced independently.

⚠ NOTE: The proper fit and adjustment of the oven door is essential for safe and reliable oven operation.

Removing/Reinstalling the Oven Door

To remove or reinstall the oven door, follow the steps below. For illustrations, see page A-4 of the Appendix.

1. Ensure the oven has cooled to 150°F (66°C).
2. Open the oven door to its full open position and insert rivets, screws, or nails as shown in Figure 74 to hold the hinges in the open position.
3. Carefully remove the oven door by pulling it up and away from the oven.
4. Reinstall (or replace) the door, verifying that the door is parallel to the oven frame. If it is not parallel, adjust the door per the adjacent instructions.
5. From Test Mode, check the status indicators “P” “S” and “M” to verify the switches engage (door closed) and disengage (door open) properly. If they do not, adjust the switches per the instructions on page 35.
6. Complete a microwave leakage test (see page 36).

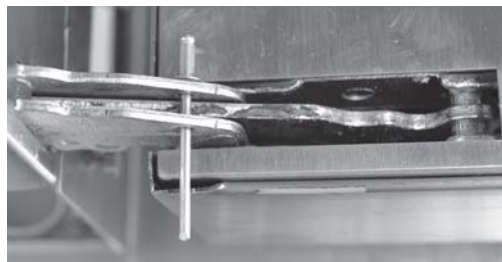

Figure 74: Insert Rivet/Screw/Nail to Keep Hinge Open

Adjusting the Oven Door

⚠ WARNING: This procedure is performed while the oven is hot. To avoid burns, be careful when adjusting the door.

1. Open the door and remove the plastic caps (four), two on each side.
2. Using a 5/32” hex key, ensure that the two socket head screws on each side of the door are tight.
3. Loosen the socket head screws and close the door.
4. Press the center of the door to allow door and frame to align properly. Do not push on either side, rather only in the center.
5. Tighten the socket head screws.
6. Plug in the oven and perform a microwave leakage test (see page 36).
7. Repeat as necessary until within specifications.
8. Reinstall the caps.

Critical Adjustment Notes

If the top or bottom of the door is rotated away from the oven cavity frame, the door is misaligned.

Corrective Action

1. Loosen the socket head screws and push the door towards the flange.
2. The hinge springs will naturally pull the door to the flange. Press the center to ensure a level surface and proper seal.

NOTE: Do not push one end at a time, which could cause the opposite end to lift away from the flange.

3. Re-tighten the socket head screws.

4. Pull the door open only 0.25" (6 mm) and let go of the handle.

The door must completely snap shut on its own. If the door sticks and force is needed to finish closing it, it is out of adjustment.

⚠ WARNING: Perform a microwave leakage test (page 36) after adjusting the oven door.

Interlock Switches

The primary, secondary, and monitor interlock switches engage and disengage in sequence to ensure a proper seal. When the door is opened, the switch sequence is P, S, M. The sequence is M, S, P as the door is closed.

Adjusting the Primary, Secondary, and Monitor Switches

⚠ WARNING: This procedure is performed while the oven is hot. To avoid burns, be careful when adjusting the switches.

Use the following procedure to adjust the primary, secondary, and monitor switches. The primary and secondary switches are located on the left side of the oven and the monitor switch is located on the right side. The switches are actuated by the a plunger switch that is engaged by the hinge as the door is closing. See pages A-6 and A-8 of the Appendix for switch assembly detail.

1. Ensure the oven has been at operating temperature for at least fifteen minutes.
2. Adjust the switch(es):
 - a. Enter Test Mode (page 18).
 - b. Open the oven door and verify P and S disengage before M.
 - c. Close the oven door and verify M engages before S, and P.
 - d. If the switches do not engage or disengage in sequence, close the door and adjust the necessary switch(es) by loosening the two #8-32 screws, adjusting the switch bracket until the proper sequence is achieved, and then re-tighten the screws.

NOTE: DO NOT allow the switch paddle to rest on the body of the switch in the closed door position. The final adjustment requires a minimum of a 0.030" (0.762 mm) gap to avoid over-travel and bent/damaged switches.

NOTE: Ensure that the #4-40 screws that secure the switches to the switch brackets are tight.

3. Open and close the door several times to verify the switch gap.
4. Perform a microwave leakage test (page 36).

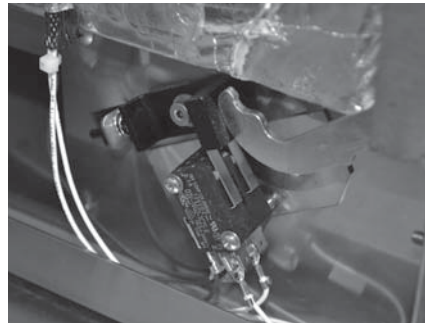

Figure 75: Primary and Secondary Switch Adjustment

Measuring RF Leakage for Microwave Safety

⚠ WARNING: This procedure requires work with hot surfaces and water loads. To avoid burns, be careful when testing.

An RF (microwave) leakage test must be performed at the conclusion of the following service tasks:

- Door removal, replacement and/or adjustment
- Waveguide removal and/or replacement
- Magnetron removal and/or replacement
- Door switch adjustment and/or replacement

⚠ WARNING: If the unit fails the microwave leakage test (leakage greater than $5\text{mW}/\text{cm}^2$), the oven must be taken out of service immediately until the defect is corrected. In addition, the CDRH Regulation 21 Subpart C, 1002.20 requires that leakage readings of over $5\text{mW}/\text{cm}^2$ must be reported to the manufacturer.

To Measure RF Leakage

1. Turn the oven on (page 7) and allow it to warm up to the set temperature (approximately 15 minutes if the oven starts cold).
2. Once the oven has warmed up, ready the oven for the test:
 - a. Place the oven in manual mode (page 11).
 - b. From manual mode, create a 1 minute recipe with a single event, 10% air, and 30% microwave.
3. Place a water load into the cook cavity. The water load must conform to the following specifications:
 - Volume: $275\text{ ml} \pm 15\text{ ml}$
 - Temperature: $68^\circ\text{F} \pm 9^\circ\text{F}$ ($20^\circ\text{C} \pm 5^\circ\text{C}$)
 - Vessel: Pyrex dish capable of 500°F
4. Close the oven door and press the Cook key. The microwave system will turn on.
5. Measure microwave emission around the door slowly as shown in Figure 76, moving the meter sensor at 0.5 inches/second.
6. As microwave leakage is observed while moving the sensor, note any meter spike areas that come close to $5\text{mW}/\text{cm}^2$ for later re-measurement.

7. Replace the water load every 60 seconds until the test is completed, and also after scanning the door.
8. Close the oven door and return the meter probe to any “meter spike” areas and allow the probe to remain in the “spike” area for 17 seconds. Note the highest reading obtained.

NOTE: There may be several places on the door where this procedure needs to be done. If so, start out with a fresh water load each time a new area is measured, or if measurement of an area takes longer than 60 seconds.

9. After each test is complete, open the oven door and dispose of the hot water. Let the steam dissipate with the door open.

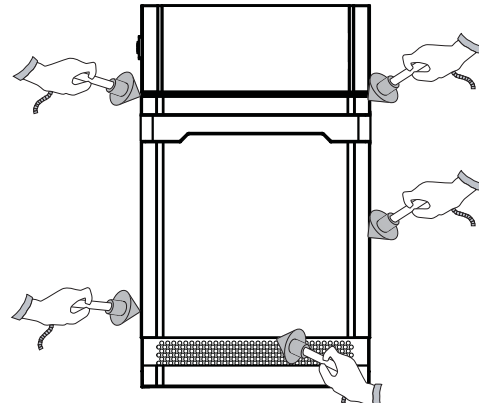

Figure 76: Survey Meter Placement

Troubleshooting

The following faults may occur in relation to the oven door:

- F3: Magnetron Current Low (see page 49)
- F4: Monitor (see page 50)

The following issues may occur in relation to the oven door:

- “Cook Door Open” message when door is closed (see page 55)

Microwave System

The ECO ST oven employs left and right microwave systems. In the case of an over-current situation, the F3 fuse will blow, shutting off both systems immediately.

This section contains information about the following components:

- Capacitor
- Filament/High-voltage transformer
- High-voltage diode
- Magnetron
- Stirrer motor and assembly
- Waveguide

This section also contains procedures for:

- Testing a capacitor
- Testing a filament portion of the transformer
- Testing a high-voltage diode
- Wiring the high-voltage transformer
- Testing a magnetron for an open/shorted filament

For information on accessing and removing parts, see the Appendix.

Capacitors

The capacitor value will vary by country. Reference the schematic (page 63) for proper values.

Testing a Capacitor

 **DANGER:** Never attempt any measurement of the capacitor while it is enabled. Lethal voltage will be present. Measure only in compliance with these procedures.

1. Disconnect the oven from the power source.
2. Fully discharge the capacitor.
3. Isolate the capacitor from the circuit.
4. Check for an open or shorted capacitor by placing ohmmeter leads between the capacitor terminals:
 - Escalating ohm readings = capacitor OK
 - Constant infinite resistance = capacitor open
 - Constant very low resistance = capacitor shorted

5. If the capacitor is not open or shorted, set the meter to measure capacitance and again place the leads between the capacitor terminals. The meter reading should equal the label value, plus or minus 4% maximum. If not, replace the capacitor.

Combination HV/Filament Transformers

The control energizes the filament portion of the transformer in combination with the high-voltage (step up) portion of the transformer.

When in operation, the filament portion of the transformer supplies approximately 3.15 VAC at 10-12 amps to the magnetron filament. The high-voltage portion of the transformer supplies the high voltage for the voltage doubler circuit.

The filament/high-voltage transformer is controlled via the K2 Anode relay.

Wiring the Transformer

 **DANGER:** Never attempt to wire or measure the secondary voltage values of the transformer. Lethal voltage will be present.

The proper reinstallation of the transformer is critical. Upon removing the transformer, make sure to note where each wire was installed. Refer to the oven schematic (page 63 for wiring detail).

With the microwave system energized, the volt meter will read the incoming voltage (different readings for different electrical installations).

The wiring must be correct prior to returning the oven to service, as the voltages must be:

- North America: 208 VAC between 1 & 2 and 240 between 1 & 3.
- International: 230 VAC between 1 & 2

NOTE: The orange wire must always go to terminal 3 on US models.

Testing the Transformer

⚠ DANGER: Never attempt to measure the secondary voltage values of the transformer. Lethal voltage will be present.

1. Disconnect the AC power source and discharge the capacitor.
2. Disconnect all the wires going to and from the transformer.
3. Use an ohmmeter to check the resistance of the primary and secondary winding. Refer to Figure 78, below, to determine if the transformer is good. If the resistance is different than the table indicates, replace the transformer.

High-Voltage Diodes

The high-voltage diode (Figure 77) is assembled by connecting several 1000-1500 volt semi-conductor diodes in a series to increase the reverse voltage capability.

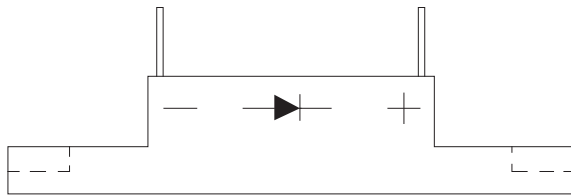

Figure 77: High-voltage Diode

In the circuit, the high-voltage diode conducts to prevent the filament voltage from becoming positive, thus as the high-voltage winding of the transformer goes to a peak of 2400 volts, the high-voltage capacitor is charged to 2400 volts.

When the high-voltage winding starts to go toward negative, the high-voltage diode becomes non-conducting with the charged high-voltage capacitor in series with the high-voltage winding. When the transformer gets to its negative peak of -2400 volts, the voltage applied to the filament is -4500 volts. The high-voltage diodes are rated at 16 kVDC.

Testing the High-Voltage Diode

⚠ DANGER: Never attempt to measure high voltage directly. Death or serious injury could result.

1. Disconnect the oven from the power source.
2. Fully discharge the capacitor.
3. Connect the voltage meter in series with the high-voltage diode.
4. Using a multimeter set to DC voltage, connect one meter lead to one side of a 9-volt battery and the other lead to one side of the high-voltage diode.
5. Connect the other side of the 9-volt battery to the other side of the high-voltage diode. DC voltage should be present on the meter in only one direction.
6. Switch the meter leads on the high-voltage diode, which will cause the opposite reading to be visible. Depending on the voltage of the battery, voltage between 5-7 VDC should be present in only one direction and 0-0.1 VDC in the other direction.

High Voltage Transformers	Primary Voltage, Frequency, Taps, and Resistance	Secondary Taps to Frame Resistance
104137	208 VAC, 60 Hz, 1 & 2, 0.93-1.14 Ω 240 VAC, 60 Hz, 1 & 3, 1.11-1.135 Ω	4 & Ground, 63.14-77.18 Ω
105258	230 VAC, 50 Hz, 1 & 2, 1.03-1.26 Ω	3 & Ground, 66.66-81.48 Ω
105244	200 VAC, 50/60 Hz, 1 & 2, 0.75-0.92 Ω	3 & Ground, 59.83-73.13 Ω

Figure 78: Transformer Resistance Table

Magnetrons

Magnetrons (Figure 79) supply RF energy at 2.45 GHz. The magnetron will start to oscillate once it is supplied with approximately 4.1 kVDC at approximately .350 mA. During operation, the magnetron will output a nominal 1 kW of power.

Perform a microwave leakage test (page 36) after installing a new magnetron or reinstalling an old one.

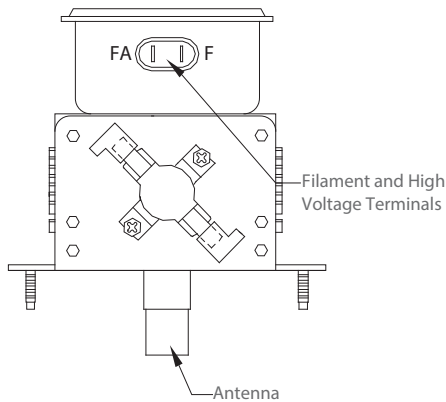

Figure 79: Magnetron

Testing a Magnetron for an Open/Shorted Filament

⚠ DANGER: The only safe way to test a magnetron is by a resistance test of its filament. Never attempt to measure the magnetron using any other method while the microwave system is on. Death or serious injury could occur.

1. Disconnect the AC power source and discharge the high-voltage capacitor.
2. Isolate the magnetron from the circuit by removing the wires from the F and FA terminals. Figure 79.
3. An ohmmeter connected between the filament terminals (F, FA) should indicate a reading of less than 1 ohm. Figure 79.
4. A continuity check between either filament terminal and the magnetron chassis should indicate an infinite resistance (open).

⚠ CAUTION: Do not allow debris to enter the waveguides when servicing the magnetrons.

Stirrer Motor and Assembly

The stirrer is responsible for evenly distributing hot air and microwave that enters the cook cavity from the top. The stirrer is driven by a 15 RPM motor, which remains on during a cook cycle or when the oven is in Test Mode.

The stirrer motor can be tested in Test Mode (see page 18).

⚠ CAUTION: Do not allow debris to enter the waveguides when servicing the stirrer.

Waveguide

The waveguide channels microwave into the cook cavity. If debris or contamination gets into the waveguide, the life of the magnetron may be shortened. Be careful to not allow debris into the waveguide when servicing the magnetrons or stirrer assembly.

Troubleshooting

The following faults may occur in relation to the microwave system:

- F3: Magnetron Current Low (see page 49)
- F5: Magnetron Over Temperature (see page 50)

The following issues may occur in relation to the microwave system:

- Food not cooking properly (see page 61).

Control System

This section contains information about the following components:

- Cooling fan
- Display and UI Control Board (Phoenix)
- Electrical compartment thermocouple
- EMI filter
- Fuses
- High-limit thermostat
- I/O Control board (Sage)
- Magnetron thermostats
- Power supply, 24 VDC
- Relay Board
- Solid state relay (K4/K5 - Heater)
- RTD
- Speaker
- Transformer thermostats
- USB
- Voltage sensor
- WiFi module
- Wire harness

Cooling Fan

The cooling fan pulls air from the front of the oven (below the oven door), it is exhausted out the back of the oven. The fan operates at 24VDC and is controlled based on oven mode:

- Warming Up: 60%
- Idle: 80%
- Cooking: 100%

The cooling fan will turn off once the oven has been below 150°F (65.6°C) for 20 minutes.

Display and UI Control Board (Phoenix)

The touch display is the primary user interface. It is a 7-in. capacitive touch screen with a tempered protective glass cover. Included with the display is the UI control board (Phoenix). The Phoenix control board handles all UI-related tasks, including graphics, menu and data storage, and programming/data transfers, via USB and Wi-Fi.

Electrical Compartment Thermocouple

The electrical compartment thermocouple is part of the Sage control board and measures the temperature of the electrical compartment. If it is above 149°F (65°C), an F6: EC TEMP fault will be displayed on the screen and logged in the fault log; however, the oven will give the user the option to continue cooking. If the thermocouple reads above 158°F (70°C), the oven will stop cooking. The control board checks the electrical compartment temperature once every 60 seconds.

EMI Filter

The EMI filter helps suppress the amount of RF interference emitted by the oven.

Fuses

The F1 and F2 fuses are 12-amp, ATMR, class CC. The F3 fuse is 25-amp, ATQR.

The F1 fuse (via brown wire) and F2 fuse (via blue wire) are designed to blow if an over-current situation is encountered by the auxiliary circuitry, including the BMSC, any cooling fan, power supply, or stirrer motor. The F3 fuse is designed to blow in case of an over-current situation relative to the microwave system (magnetron, transformer, diode, capacitor), or if the microwave system is on when the M (monitor) switch opens, indicating a door alignment/adjustment issue. The fuses are located on the Relay Board.

High Limit Thermostat

The high limit thermostat is a 250 VAC, 3-pole, manual-reset thermostat with a trip point of 572°F (300°C). The thermostat interrupts power to the main convection heater in the event of an abnormal condition. Reset the high-limit thermostat by pressing the reset button (Figure 80).

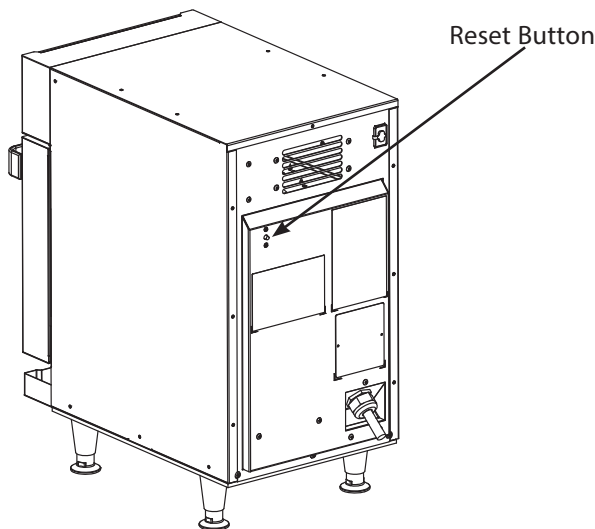

Figure 80: High-Limit Reset Button

I/O Control Board (Sage)

The I/O control board (Sage) controls each electrical component of the oven. 24 VDC can be measured at pin 2 of the J7 connector to confirm control voltage is being applied (see page 63).

Magnetron Thermostats

The magnetron thermostats are “open-on rise.” They are designed to open at 270°F (132°C), which triggers an F5 fault.

NOTE: When open, the control will switch off the magnetrons until the open thermostat closes. The thermostats are self-resetting.

Power Supply

The power supply outputs 24 VDC at 40 watts to the control board, relay board, speaker, and display/UI board.

Relay Board

The relay board combines the voltage module, fuses, and the relays listed below into a single control board.

K2 - Monitor relay

K3 - Anode relay

K6A - Magnetron 1 voltage relay

K6B - Magnetron 2 voltage relay

K8 - Stirrer Motor

The fuses, voltage module, and K2 and K3 relays can be serviced independently. The K2/K3 relay is a 240 VAC, 30 amp, double-pole, double-throw, 24 VDC relay coil. See schematic on page 63 for relay locations.

Solid State Relay - K4/K5 Heater

The solid state relay is a 240 VAC, dual 40-amp relay. K4 switches power to the bottom heater, and K5 switches power to the top heater.

RTD

The RTD measures the temperature of the heater element. If the display reads “999°F/C”, the RTD is open, resulting in an F7 or F9 fault. See pages 51 and 52 for troubleshooting.

Testing Procedure:

1. Disconnect the RTD from the control harness.
2. Place the RTD in ice water for two minutes.
3. Take a resistance reading of the RTD.
4. If RTD resistance is not 100 Ω, the RTD is defective and must be replaced.

NOTE: Use Figure 81, page 42 to determine resistance readings at temperatures other than freezing.

Speaker

The speaker provides audible feedback to the oven operator whenever a key is pressed or a task (such as a cook cycle) is completed.

Transformer Thermostats

The transformer thermostats are “open-on rise” and are designed to open at 280°F (138°C). When open, power is interrupted to the transformer.

The thermostats are self-resetting.

NOTE: The transformer thermostats are NOT interchangeable with the magnetron thermostats.

USB

The USB allows the oven operator to load menus and firmware updates to and from a USB thumb drive. For instructions, see pages 20-21.

Voltage Sensor

For North America models only. Voltage selection is completed at the time of manufacture; however, if incoming voltage for the store is different than the preset voltage, the operator will be required to select either 208 or 240 after turning on the oven. The correct voltage will be enlarged on the screen, identifying which option to select. The voltage sensor is a replaceable module that is part of the relay board. See schematic on page 63 for voltage sensor location.

WiFi Module

The WiFi module allows the oven to connect to the internet via the store’s access point, provided the user authorizes access and the preset credentials are entered (see page 15). WiFi must be specified at the time of the manufacture; otherwise the Eco oven will not include the WiFi module.

Wire Harness

The wire harness distributes power to the oven’s electrical components. See page 63 for a schematic.

Troubleshooting

The control system could potentially be related to the cause of any fault (see pages 45-53 for detailed fault troubleshooting).

The control system might also be related to any issue diagnosed in the section “Non-Fault Code Troubleshooting” on pages 54-62.

°F	0°	+20°	+40°	+60°	+80°	+100°	+120°	+140°	+160°	+180°	+200°
0°	90.03 Ω	97.39 Ω	101.74 Ω	106.07 Ω	110.38 Ω	114.68 Ω	118.97 Ω	123.24 Ω	127.50 Ω	131.74 Ω	135.97 Ω
+200°	135.97 Ω	140.18 Ω	144.38 Ω	148.57 Ω	152.74 Ω	159.90 Ω	161.04 Ω	165.17 Ω	169.29 Ω	173.39 Ω	177.47 Ω
+400°	177.47 Ω	181.54 Ω	185.60 Ω	189.64 Ω	193.67 Ω	197.69 Ω	201.69 Ω	205.67 Ω	209.64 Ω	213.60 Ω	217.54 Ω
+600°	217.54 Ω	221.47 Ω	225.38 Ω	229.28 Ω	233.17 Ω	237.04 Ω	240.90 Ω	244.74 Ω	248.57 Ω	252.38 Ω	256.18 Ω
°C	0°	+10°	+20°	+30°	+40°	+50°	+60°	+70°	+80°	+90°	+100°
0°	100.00 Ω	103.90 Ω	107.79 Ω	111.67 Ω	115.54 Ω	119.40 Ω	123.24 Ω	127.07 Ω	130.89 Ω	134.70 Ω	138.50 Ω
+100°	138.50 Ω	142.29 Ω	146.06 Ω	149.82 Ω	153.58 Ω	157.31 Ω	161.04 Ω	164.76 Ω	168.46 Ω	172.16 Ω	175.84 Ω
+200°	175.84 Ω	175.91 Ω	183.17 Ω	186.82 Ω	190.45 Ω	194.07 Ω	197.69 Ω	201.29 Ω	204.88 Ω	208.45 Ω	212.02 Ω
+300°	212.02 Ω	215.57 Ω	219.12 Ω	222.65 Ω	226.17 Ω	229.67 Ω	233.17 Ω	236.65 Ω	240.13 Ω	243.59 Ω	247.04 Ω

Figure 81: Temperature/Resistance Relationship Class B. Resistance @ 0°C = 100.0, Alpha = 0.003850

Filtering System

This section contains information about the following components:

- Catalytic converter
- Air filter

Catalytic Converter

The catalytic converter, a VOC type catalyst, is located behind the inside cook cavity wall and is responsible for cleaning the recirculating airflow. The catalyst functions by substantially lowering the combustion temperature of grease entrained in the air path to approximately the same temperature of the airflow; thus the grease burns and breaks down into CO₂ and H₂O as it passes through the catalytic converter. The catalyst will operate most efficiently at temperatures above 475°F (246°C).

The catalyst material is very sensitive to certain chemical compounds. Irreversible damage can occur if the catalyst is exposed to cleaning chemicals containing phosphates, NaOH, silicates, Na and Potassium Salts. These chemicals are found in most commercial degreasers and cleaners; therefore, only TurboChef® Oven Cleaner should be used.

 **CAUTION:** Clean the catalytic converter with TurboChef Oven Cleaner and rinse thoroughly with distilled water. Let the catalytic converter air dry before reinstalling. If TurboChef Oven Cleaner is not available, use only distilled water.

Air Filter

The filter is located on the front of the oven, below the door. It helps prevent debris from getting into the electrical compartment. This component requires daily rinsing and occasional replacement, as it must be kept clean and in good working condition to ensure proper air circulation to the electrical components of the oven. See page 5, step 4 for details.

Troubleshooting

The following issues may occur in relation to the filtering system:

- F9: CC Temp (if the catalyst is clogged with grease and debris, see page 52).
- Fire in the cook cavity (if catalytic converter is clogged and oven is not regularly cleaned).
- Electrical component failure (if filter is not present or is clogged).
- Undesirable flavor transfer or odors.

This page intentionally blank.

Troubleshooting

Overview of Troubleshooting

This section contains information on the following:

- Fault code descriptions
- Fault code troubleshooting
- Non-fault code troubleshooting

For information on accessing Test Mode, see page 18. For information and illustrations on replacing components, see the appendix.

Fault Code Descriptions

To view the fault log see page 17.

F1: Blower Running Status Bad

This fault is displayed when the motor controller indicates no running status.

The motor and motor controller are monitored continuously in all modes with special handling in the Test Mode (page 18). If a fault is detected, the control will terminate a cook cycle and display “F1: Blower.”

Upon turning on the oven, the control will attempt to restart the motor. If the restart is successful, the fault code will be cleared from the display. The fault is also cleared from the display at the onset of cooking or when the blower motor is tested in Test Mode.

F2: Cook Temperature Low

This fault is displayed if the cook cavity temperature is more than 84°F (47°C) below the set temperature after five seconds into a cook cycle.

The fault is cleared from the display at the onset of cooking if the cook cavity temperature is within 84°F (47°C) of the set temperature or when the heater is tested in Test Mode (page 18).

F3: Magnetron Current Low

This fault is displayed when the current transformer (CT) on the I/O control board detects less than 7 amps. The fault is monitored when the microwave is on during a cook cycle or in Test Mode.

The fault is cleared from the display at the onset of a cook cycle if the CT detects 7 amps, or when the magnetron is successfully energized in Test Mode.

F4: Door Monitor Defective

This fault is logged when the control detects that the monitor interlock switch opens before the primary or secondary interlock switches. In addition, this fault will blow the F3 fuse if the microwave high voltage system is energized when the fault occurs. The fault is cleared from the display when the oven is powered off and then back on.

NOTE: Door interlock switches are in parallel. See the oven schematic, page 63. The fault is monitored during a cook cycle and in Test Mode when the microwave is on.

F5: Magnetron Over Temperature

This fault is displayed when the magnetron thermostat reaches 270°F (132.2°C).

The thermostat will reset automatically. The fault is cleared from the display at the onset of a cook cycle if the thermostat is closed.

F6: Electrical Compartment Temperature High

This fault is displayed when the EC thermocouple, located on the Sage Board, exceeds 149°F (65°C). If the thermocouple reads above 158°F (70°C), the oven will stop cooking. The EC temperature is monitored once per minute.

The fault is cleared from the display if on the next check, the EC thermocouple temperature is below 149°F (65°C).

F7: RTD Open

This fault is displayed when the control detects that the RTD is “open.” The display will show a reading of “999°F/C,” indicating the RTD is open. The fault is cleared when the control detects continuity.

F8: Heat Low

This fault displays when the oven is warming up or during Test Mode if the cook cavity temperature fails to rise at least 14°F (7°C) within a given 60 seconds.

F9: Cook Cavity Temperature High

This fault will signal that the catalyst has “flashed” due to excessive grease. The fault occurs when the RTD senses +650°F (343°C) for more than 40 seconds but less than 2 minutes. The fault will only appear in the fault log and will not terminate a cook cycle upon discovery.

F10: Communication Failure

This fault will signal that the UI control board (Phoenix) is no longer able to communicate with the I/O control board (Sage). This fault will terminate a cook cycle upon discovery.

F12: Firmware Reboot

This fault will signal that the processor on the UI control board (Phoenix) has become unresponsive for four seconds, forcing a system reboot.

F13-1: Cooling Fan Unresponsive

This fault will signal that the cooling fans’ reported RPMs are not inline with what was commanded.

F13-2: Cooling Fan Not Operating

This fault is displayed when the cooling fan indicates no running status.

The cooling fan is monitored continuously in all modes. If a fault is detected, the control will terminate a cook cycle and display “F13-2: Cooling Fan Not Operating.”

Upon turning on the oven, the control will attempt to restart the cooling fan. If the restart is successful, the fault code will be cleared from the display. The fault is also cleared from the display at the onset of cooking or when the cooling fan is tested in Test Mode.

Fault Code and Description	When Active				Refer to...
	Warmup	Idle	Cooking	Test Mode	
F1: Blower Running Status Bad	✓	✓	✓	✓	Page 47
F2: Cook Temperature Low			✓		Page 48
F3: Magnetron Current Low			✓	✓	Page 49
F4: Door Monitor Defective			✓	✓	Page 50
F5: Magnetron Over Temperature			✓	✓	Page 50
F6: EC Temperature High	✓	✓	✓	✓	Page 51
F7: RTD Open	✓	✓	✓	✓	Page 51
F8: Heat Low	✓			✓	Page 52
F9: Cook Cavity Temperature High		✓	✓	✓	Page 52
F10: Communication Failure	✓	✓	✓	✓	Page 53
F12: Firmware Reboot	✓	✓	✓	✓	Page 53
F13-1: Cooling Fan Unresponsive	✓	✓	✓	✓	Page 54
F13-2: Cooling Fan Not Operating	✓	✓	✓	✓	Page 54

Figure 82: Fault Code Descriptions

Fault codes are listed in order of hierarchy. For example, if during cooking the oven experiences an F1 and F2 fault, the oven will report only the F1 fault because the software will halt all actions upon discovering the F1 fault.

FAULT CODES F1 - F5, F7, F10, F12, AND F13-2 WILL TERMINATE A COOK CYCLE UPON DISCOVERY.

Fault Code Troubleshooting

From Test Mode, you can run oven diagnostics and check fault counts. To access Test Mode or turn on Diagnostic mode, see page 18. To locate oven components for testing, adjustment, or replacement, see the Appendix.

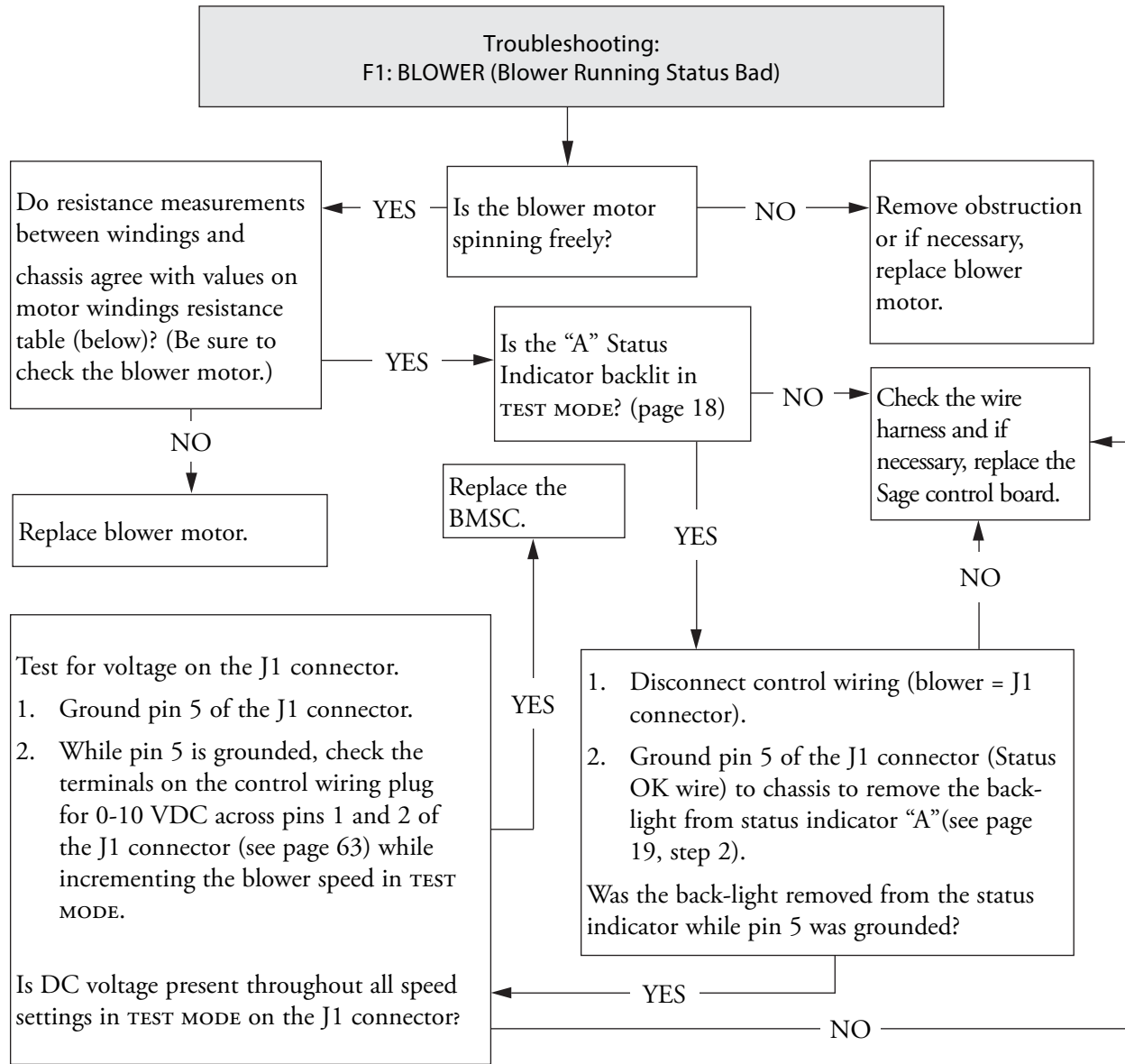

To	From	Description	Expected Resistance
Black	Red	Winding (A-B)	5.9-7.3 Ohms
Black	White	Winding (A-C)	5.9-7.3 Ohms
Red	White	Winding (B-C)	5.9-7.3 Ohms
Black, Red, or White	Green	Windings to Chassis	Open

Figure 83: Motor Windings Resistance Table

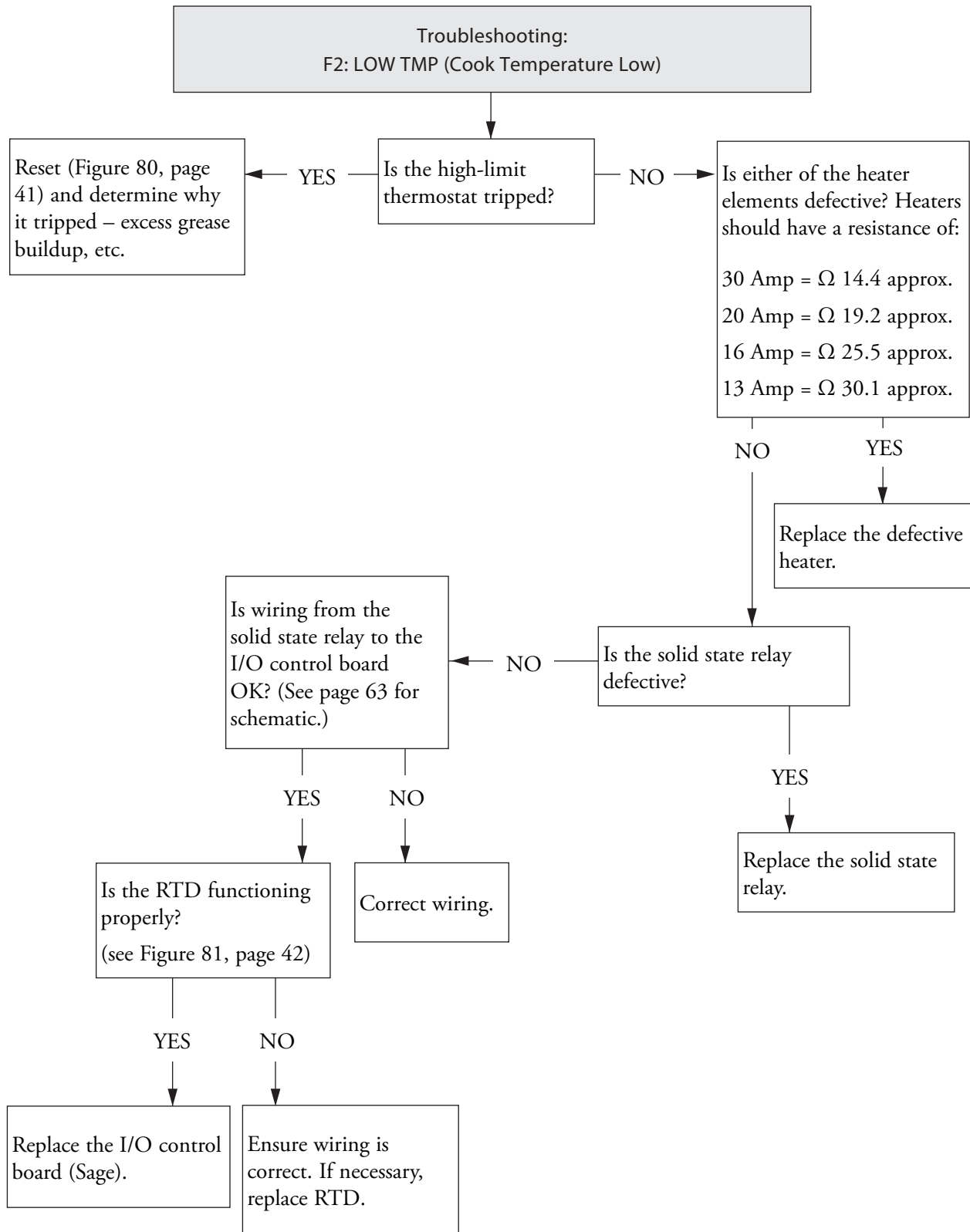

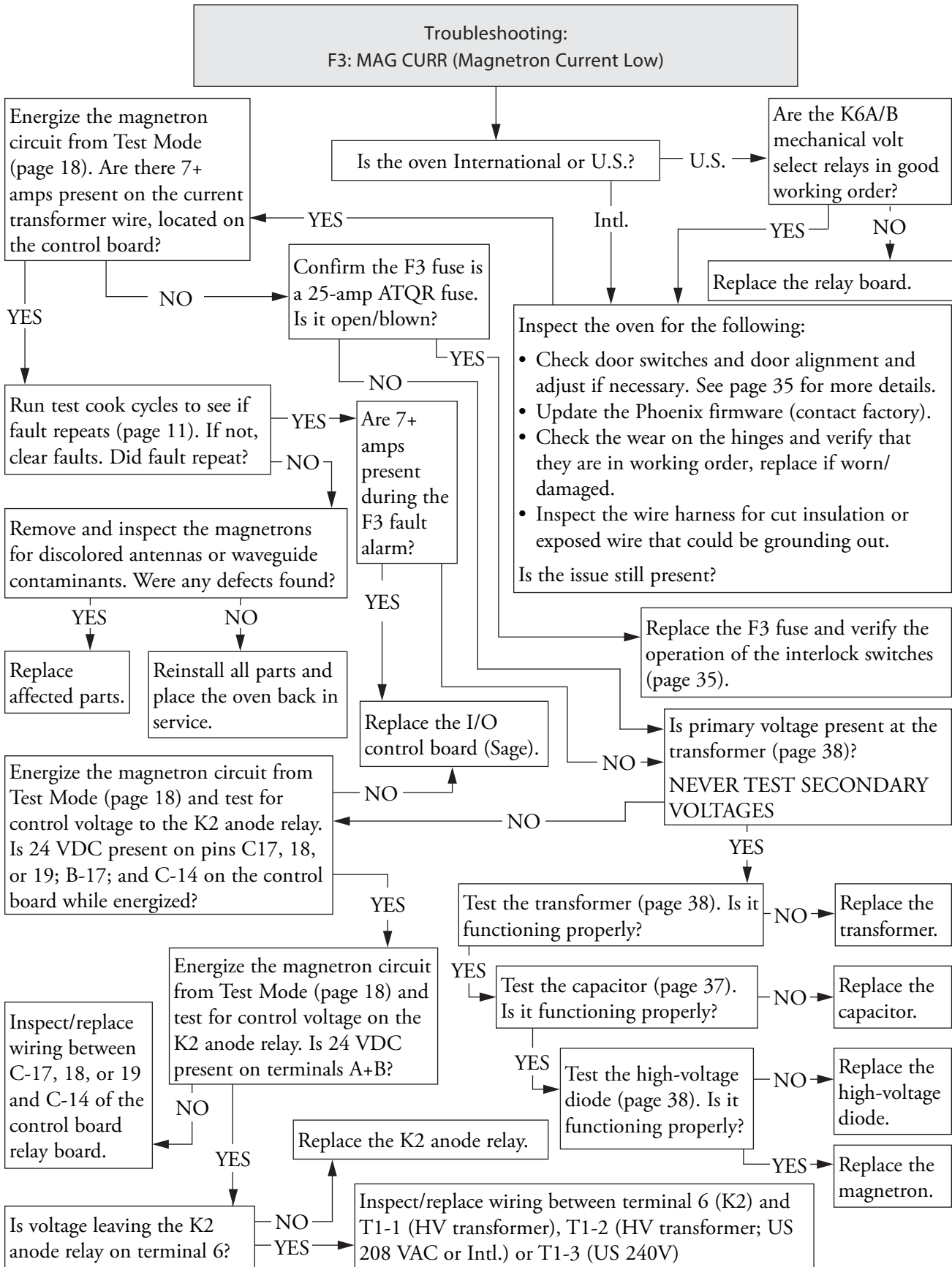

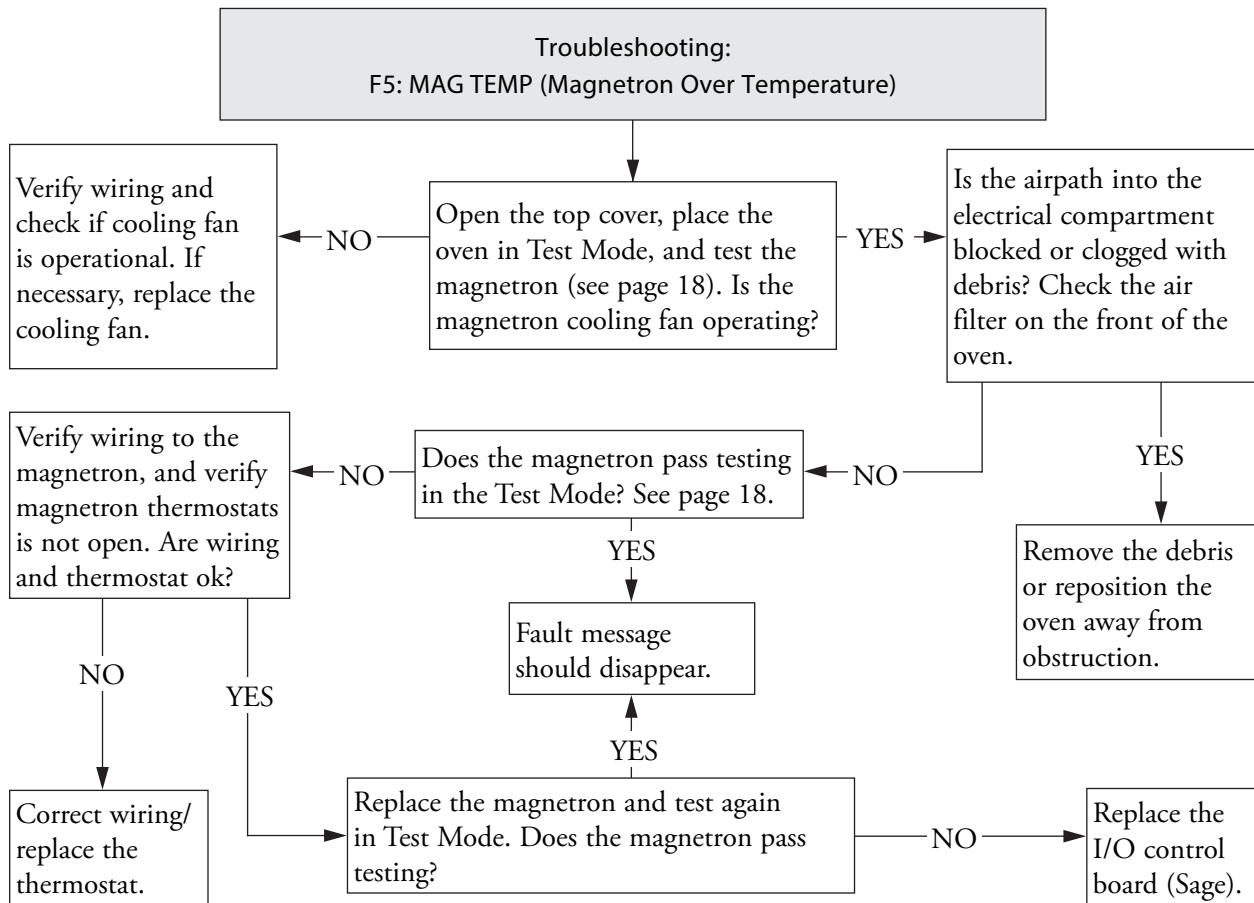
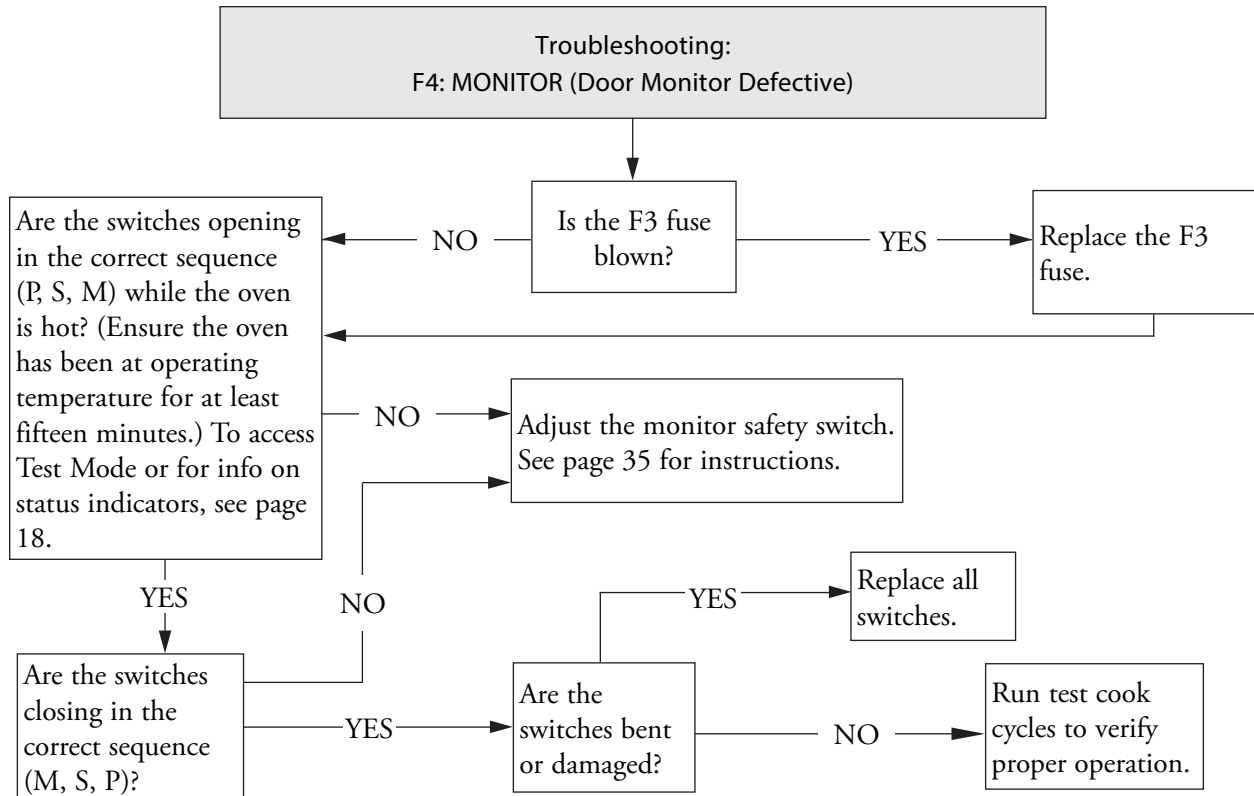

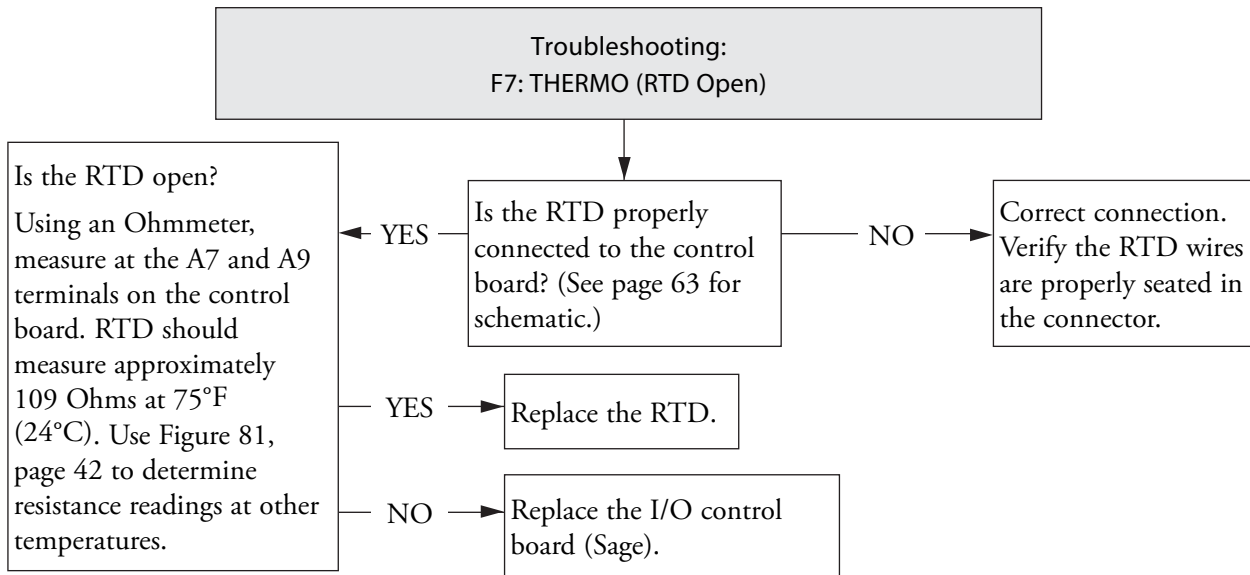
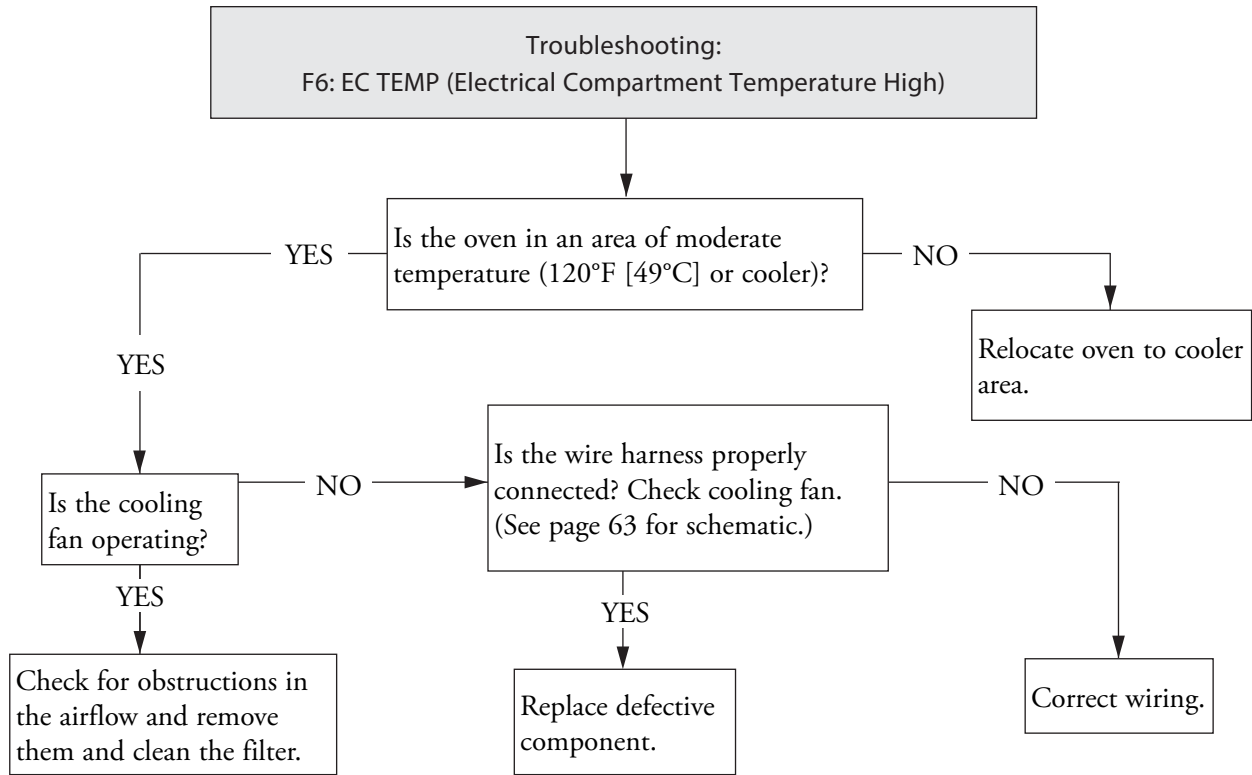

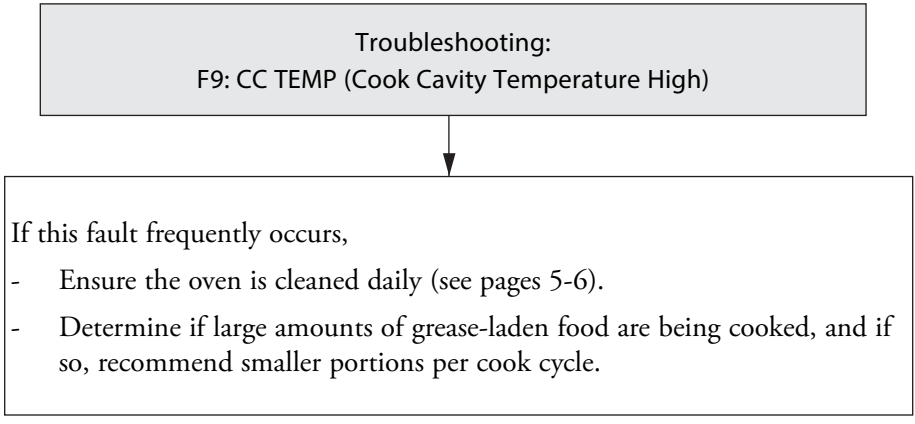
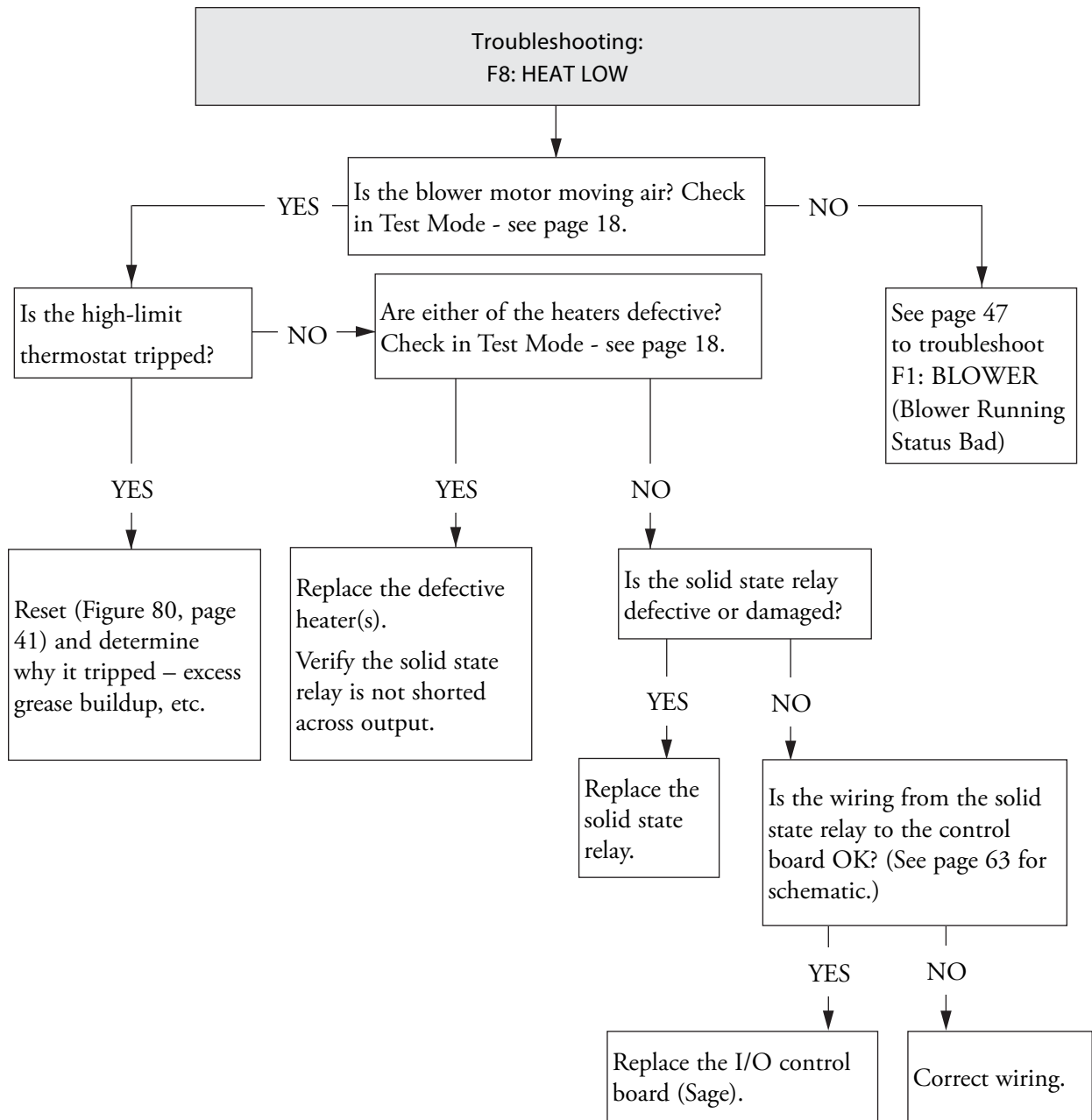

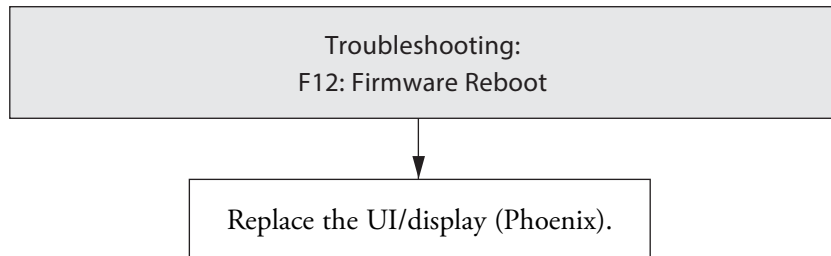
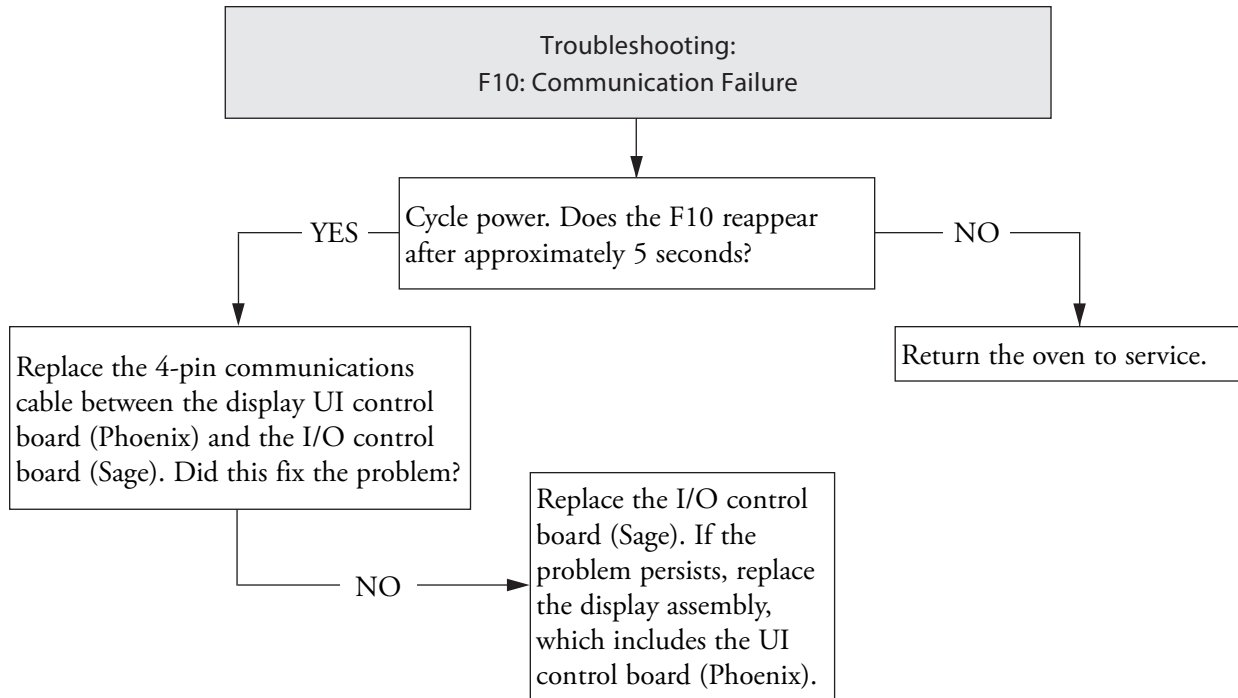

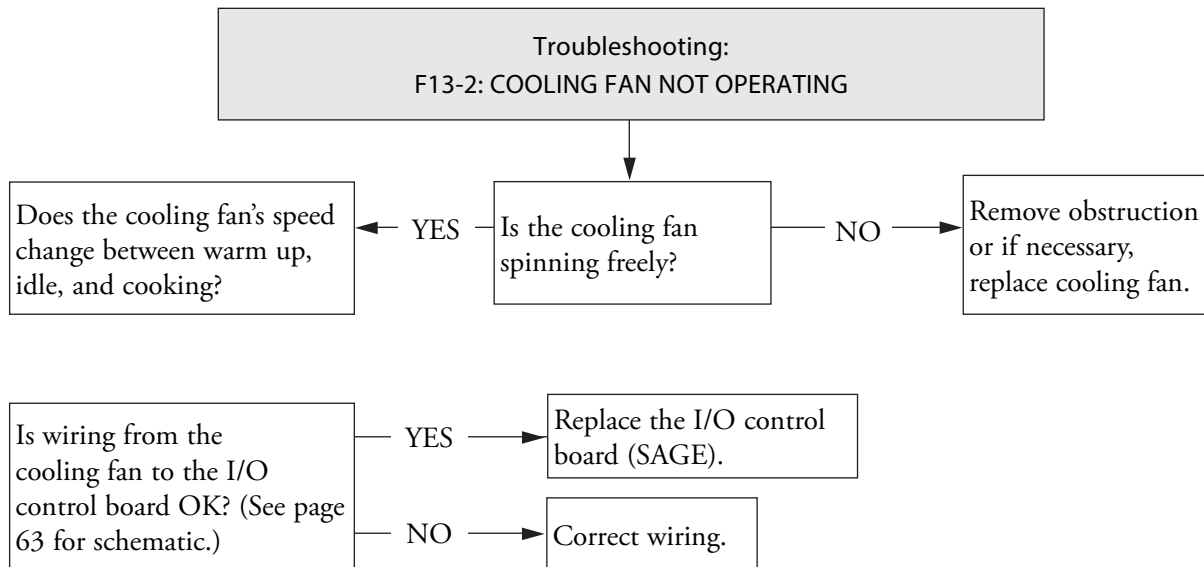
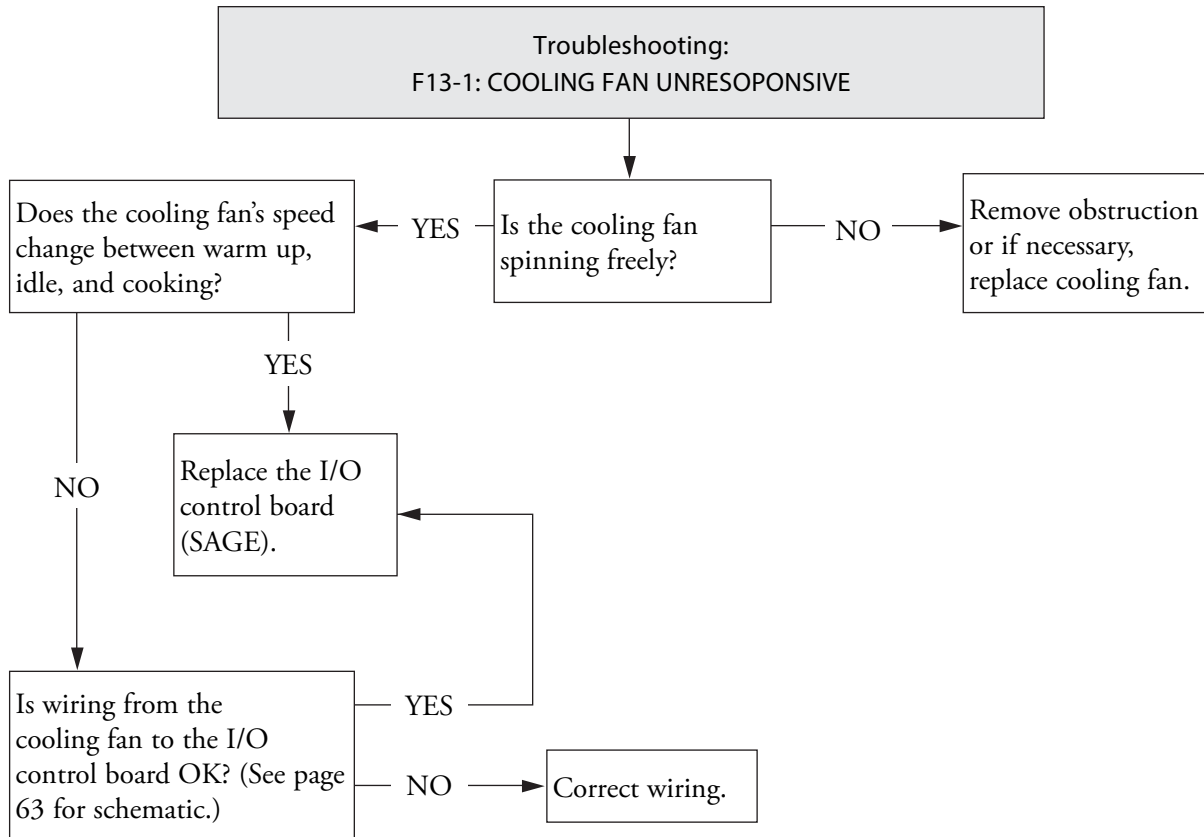

Non-Fault Code Troubleshooting

This section provides troubleshooting tips for issues that may occur independently of an oven fault.

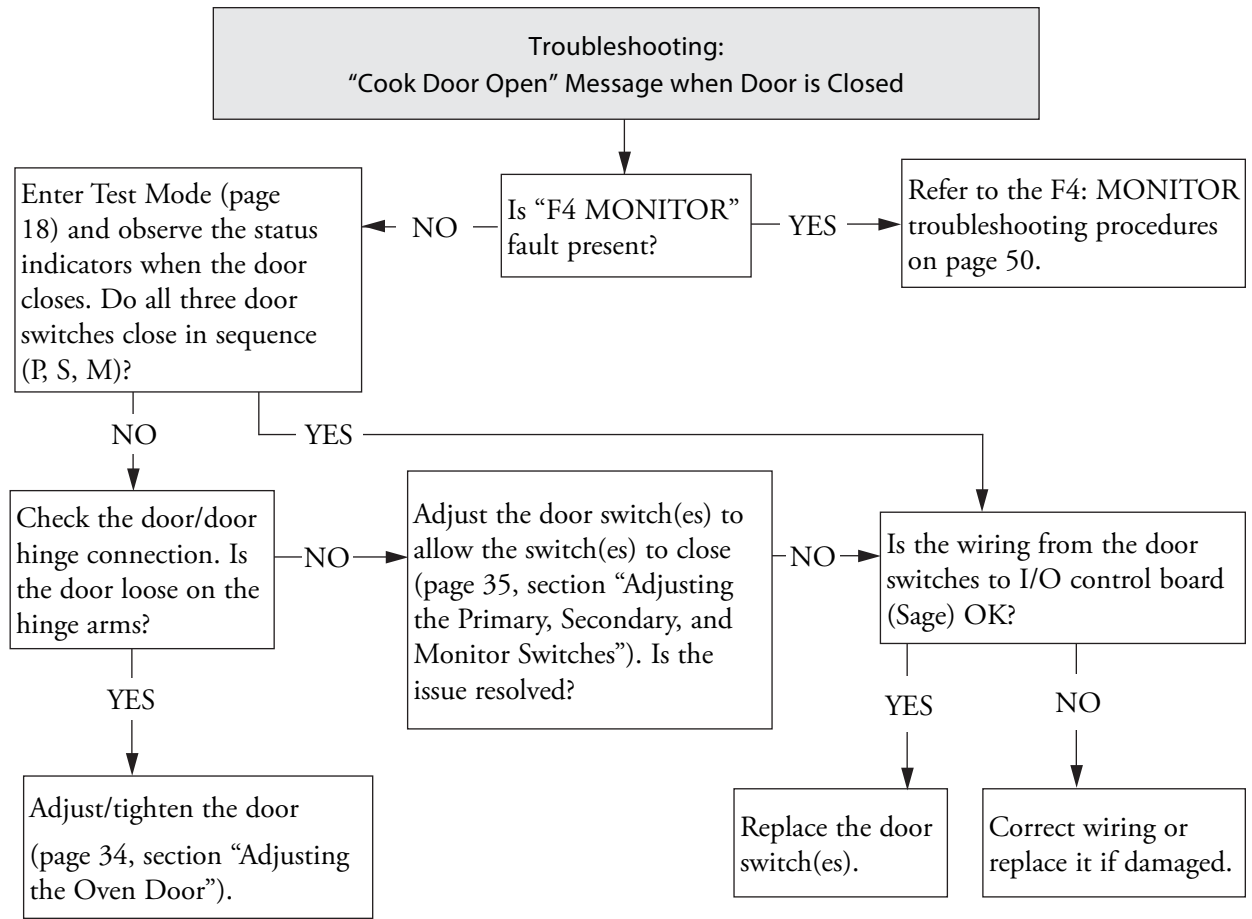

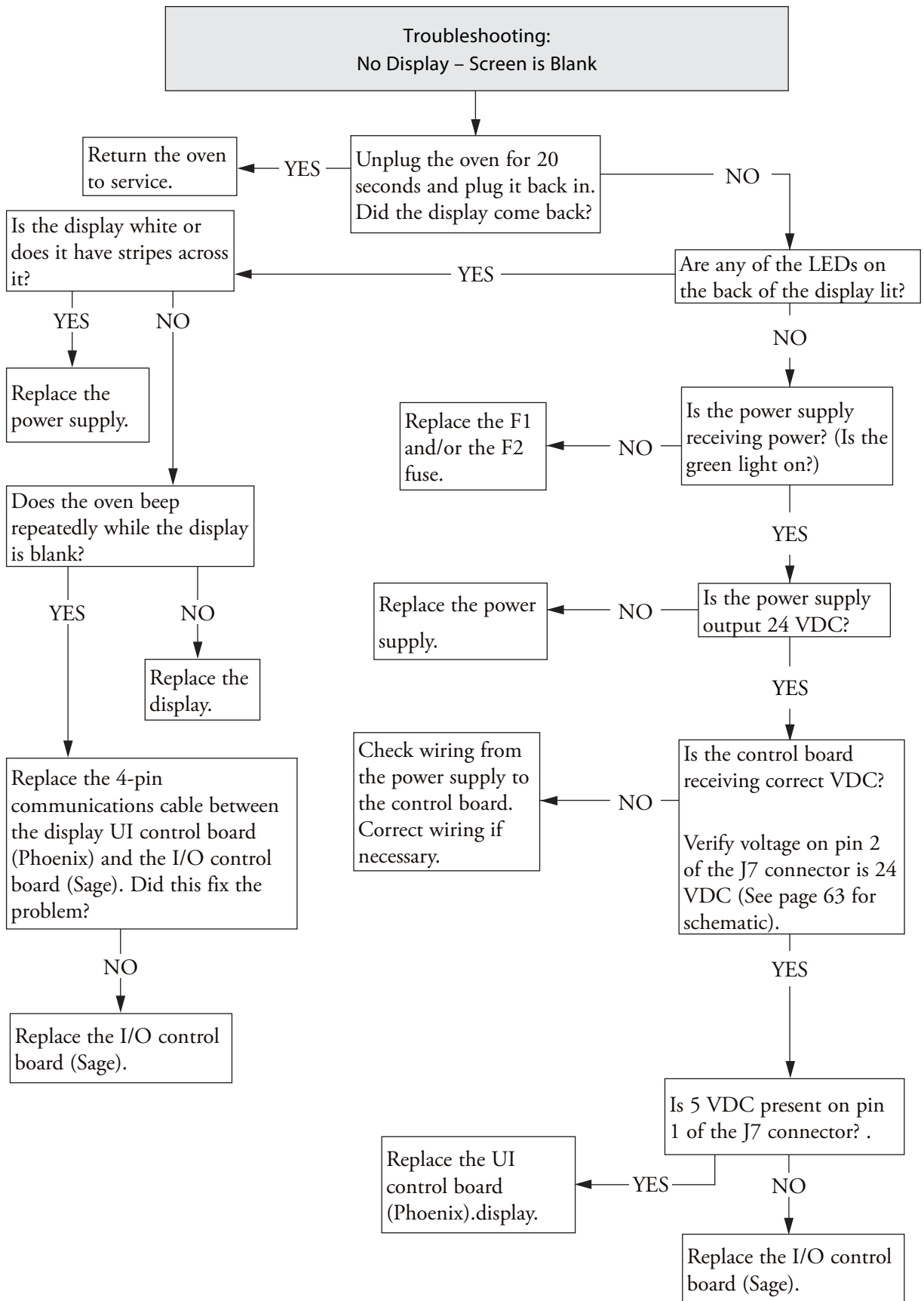

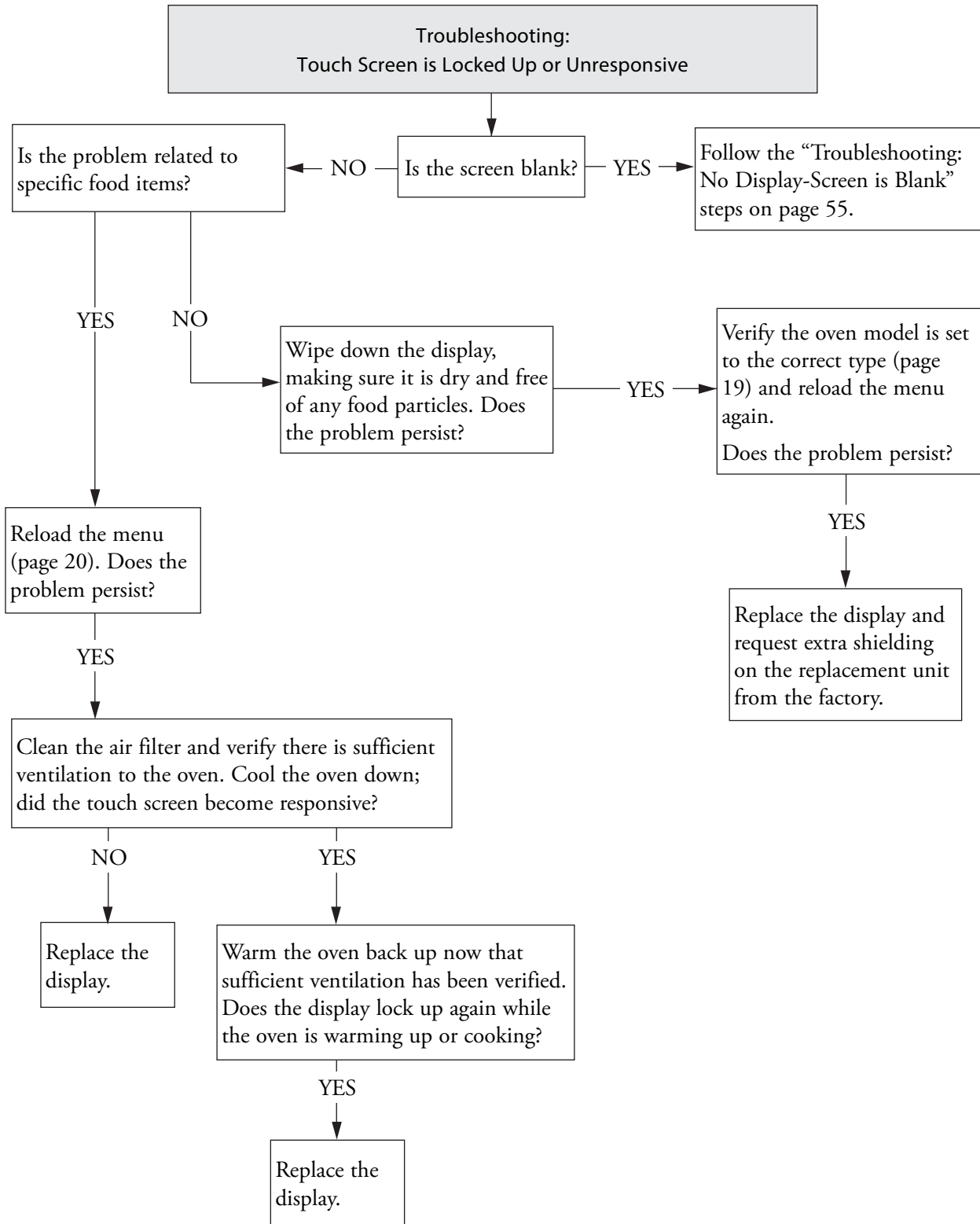

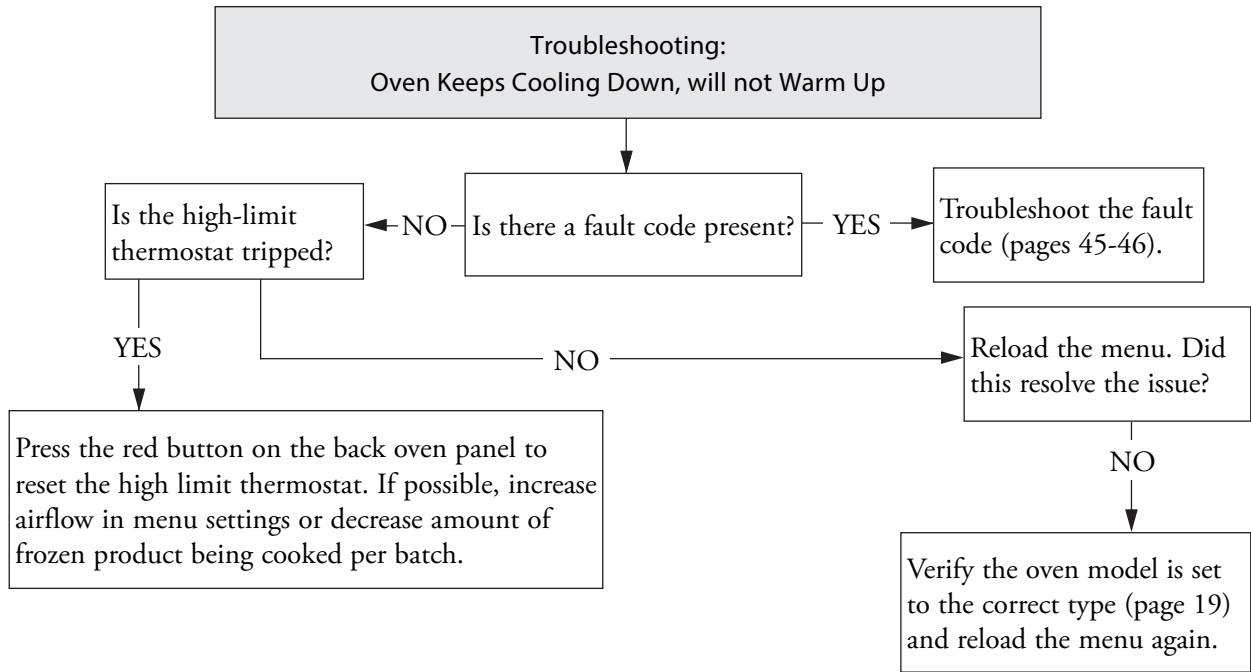

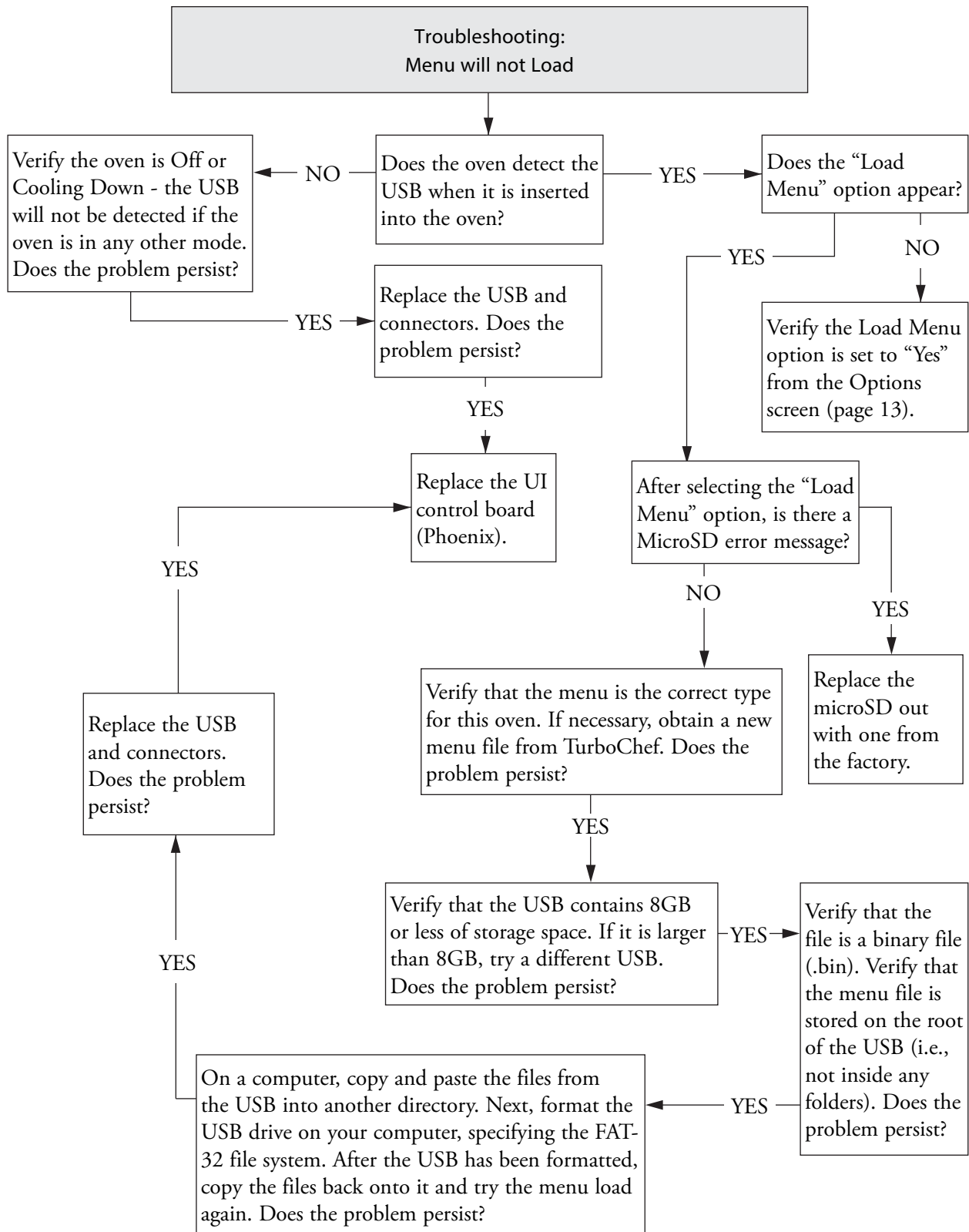

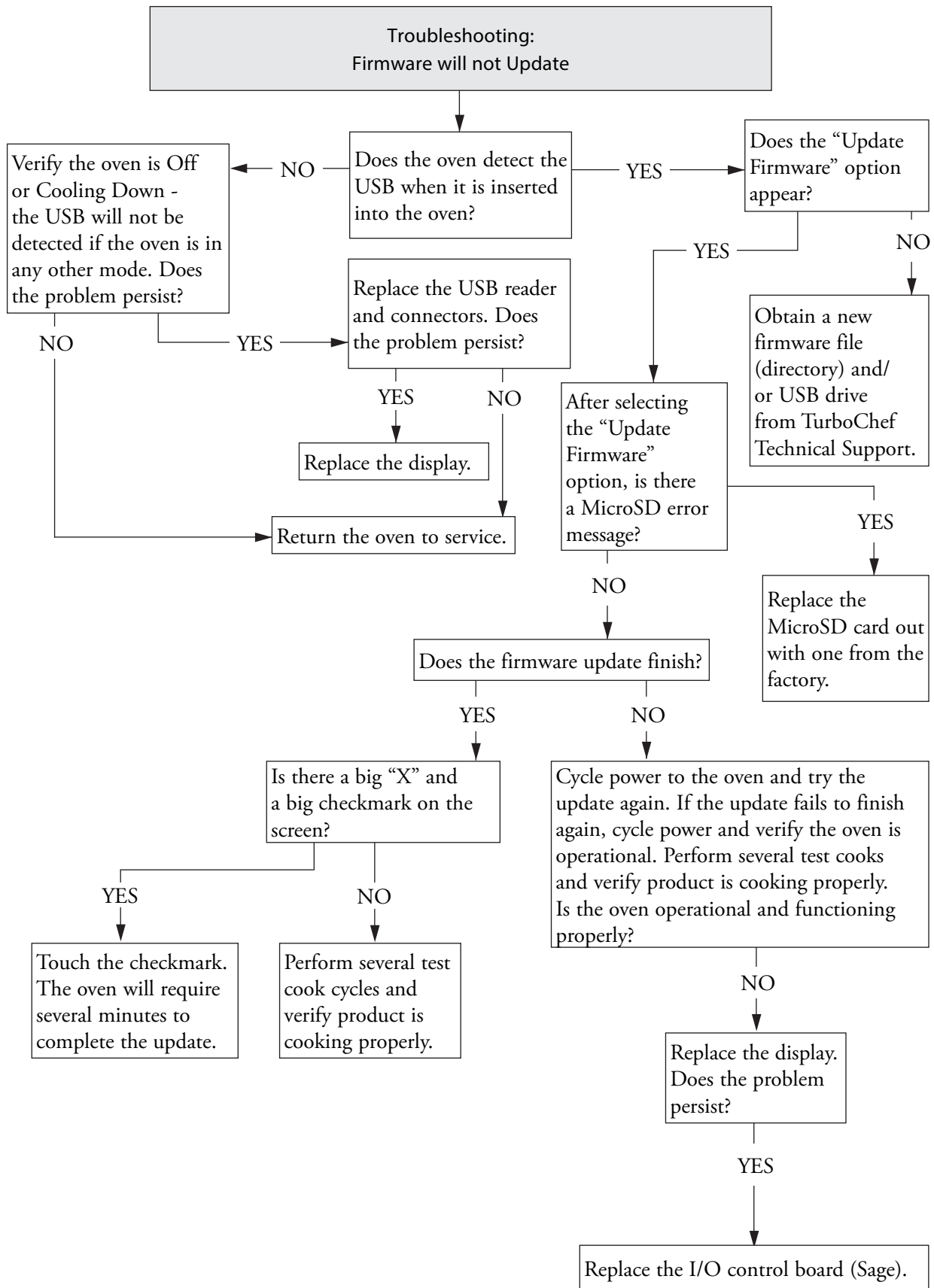

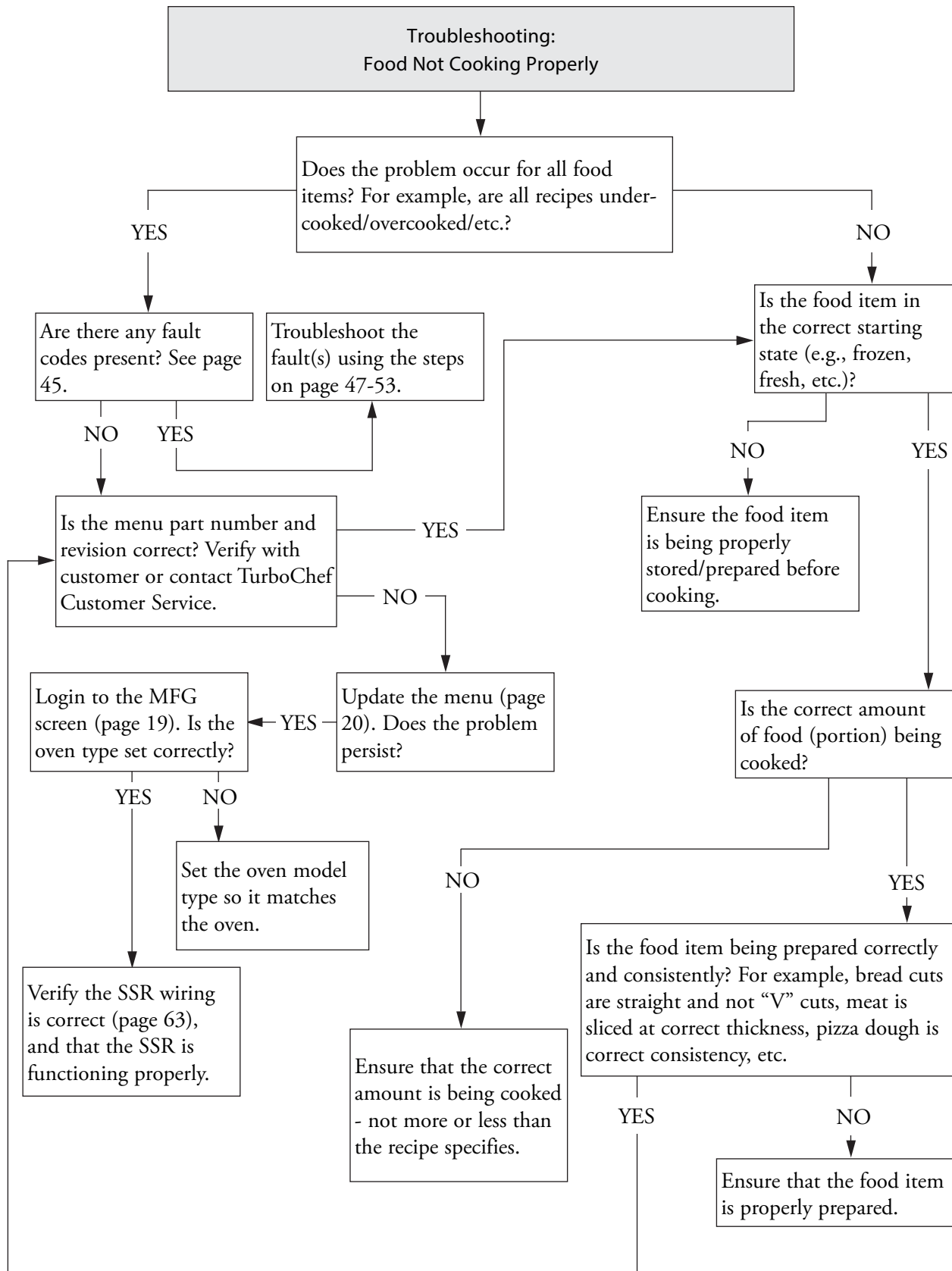

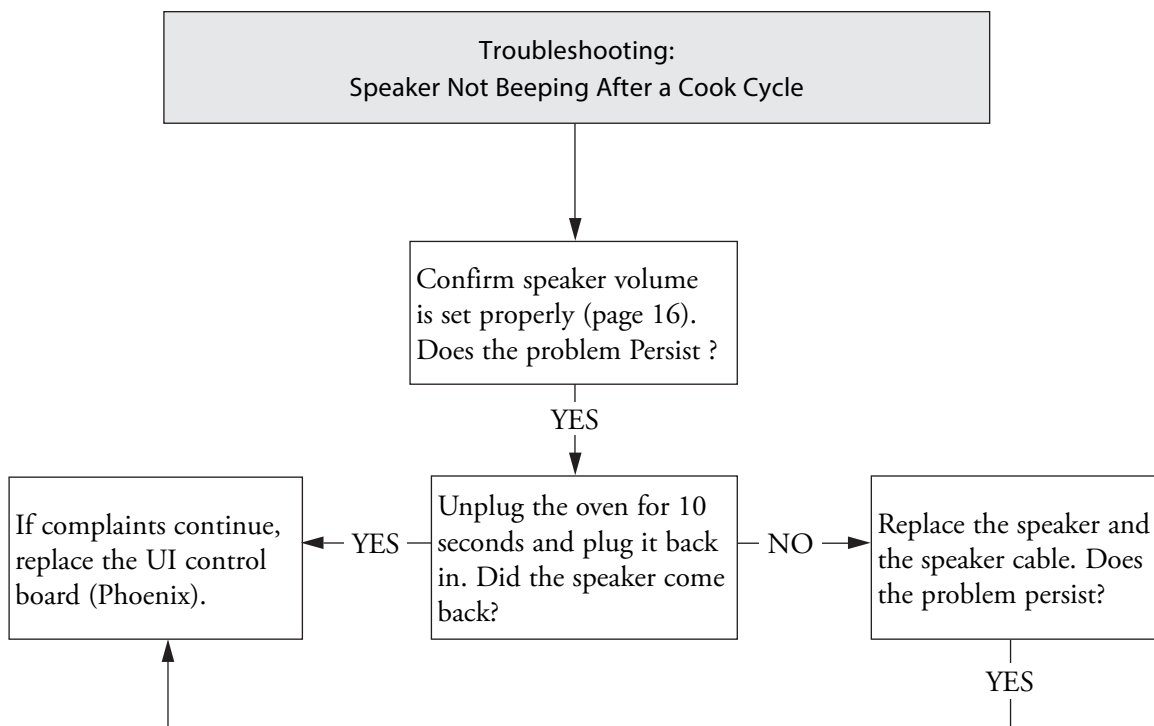

Oven Schematic

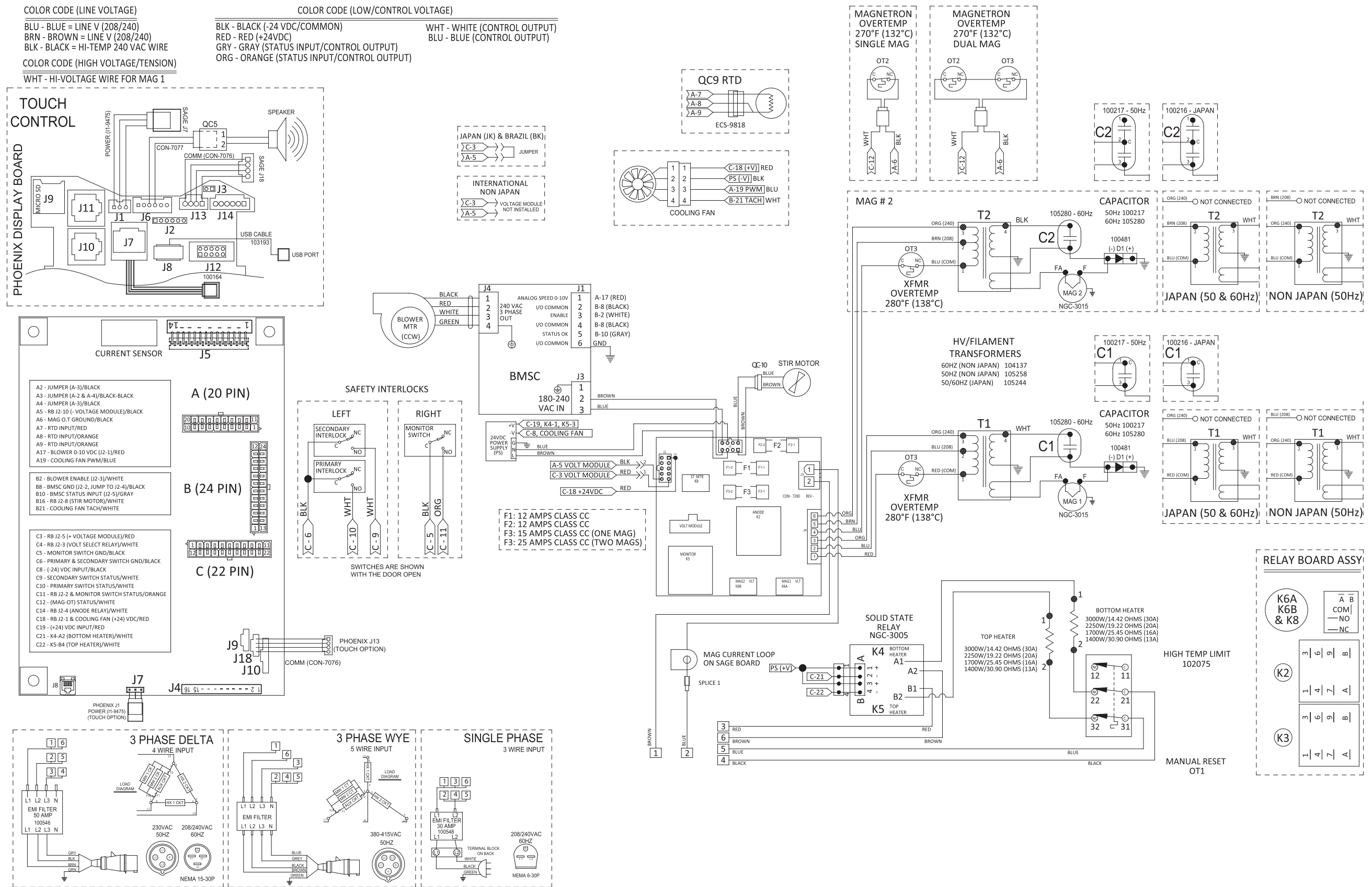

Figure 84: Oven Schematic

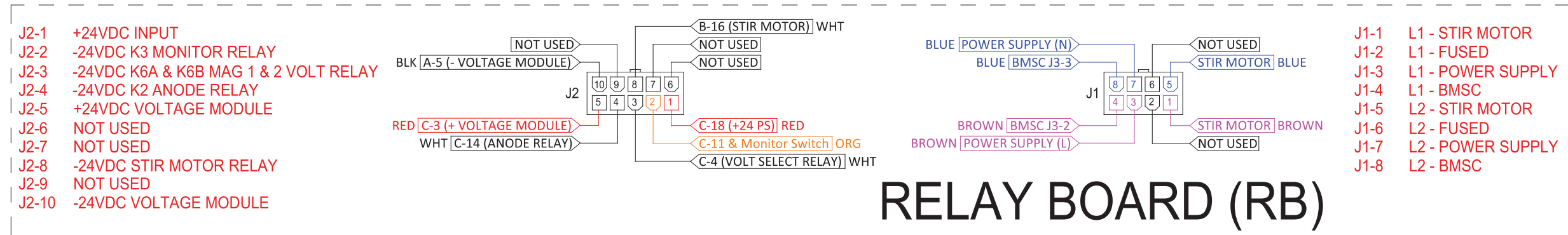
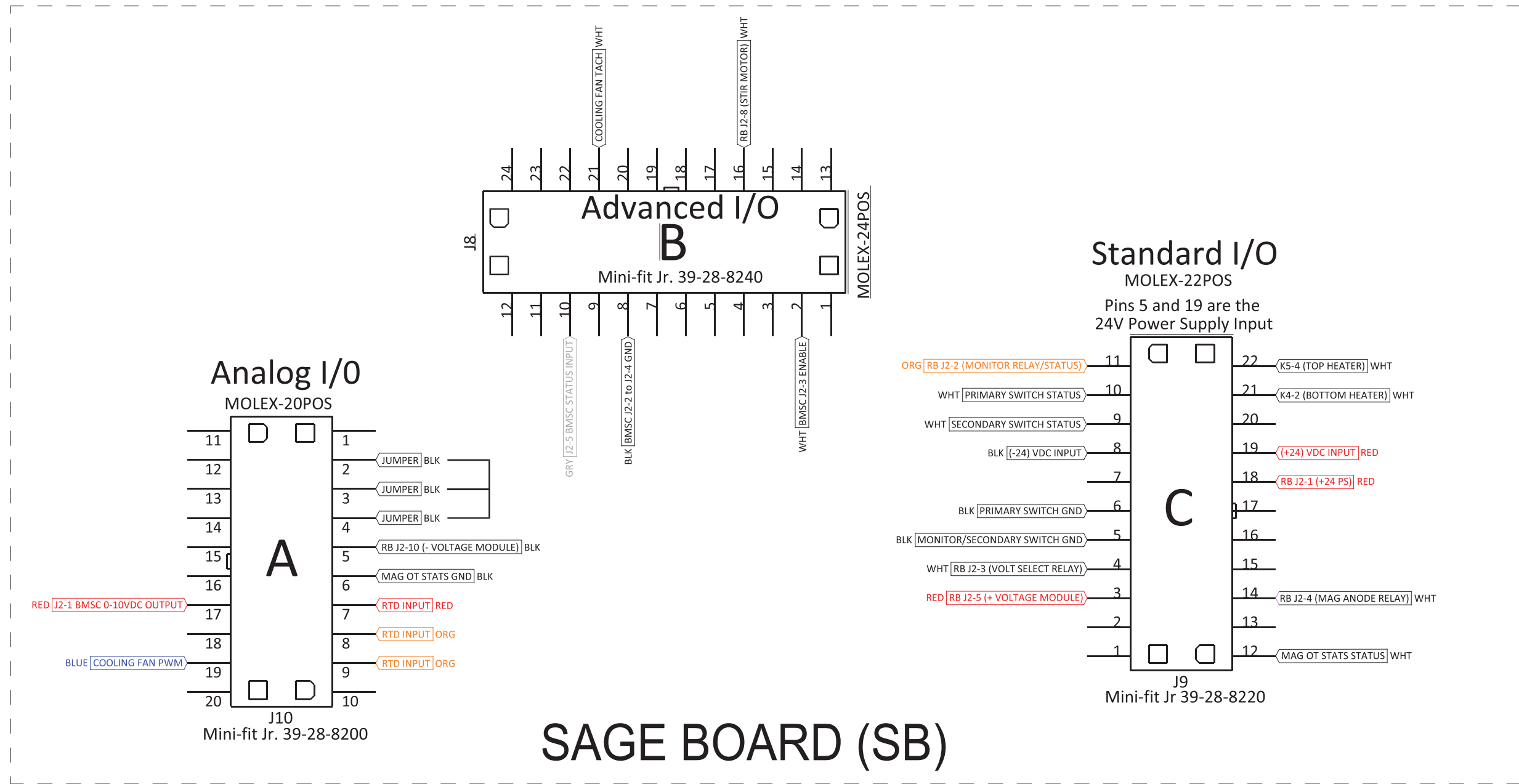

Figure 85: Oven Schematic - I/O Detail

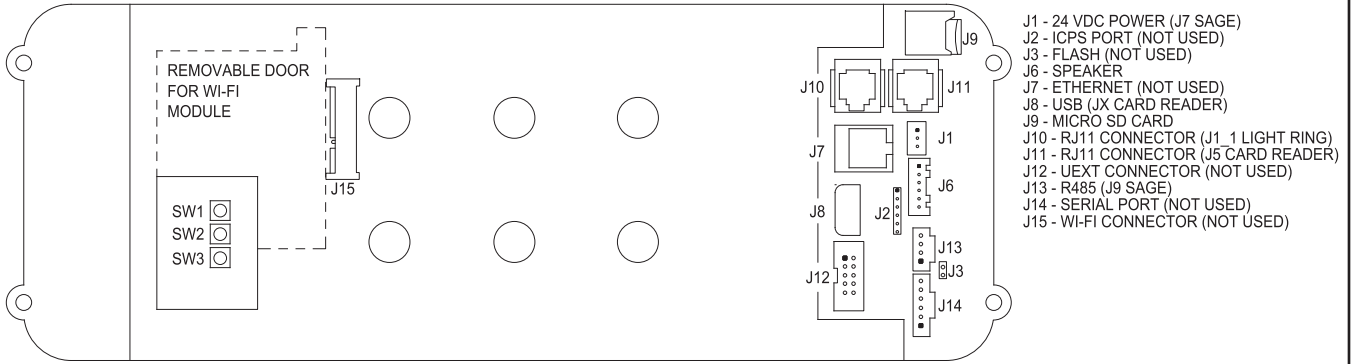

Figure 86: Phoenix Display Board Connector Detail

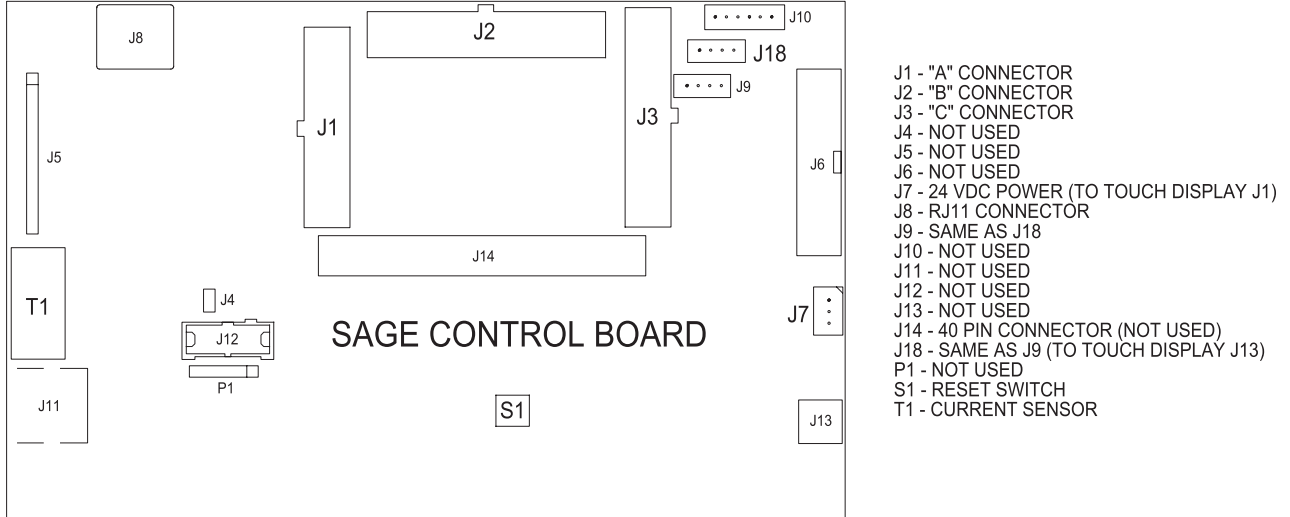

Figure 87: Sage Control Board Connector Detail

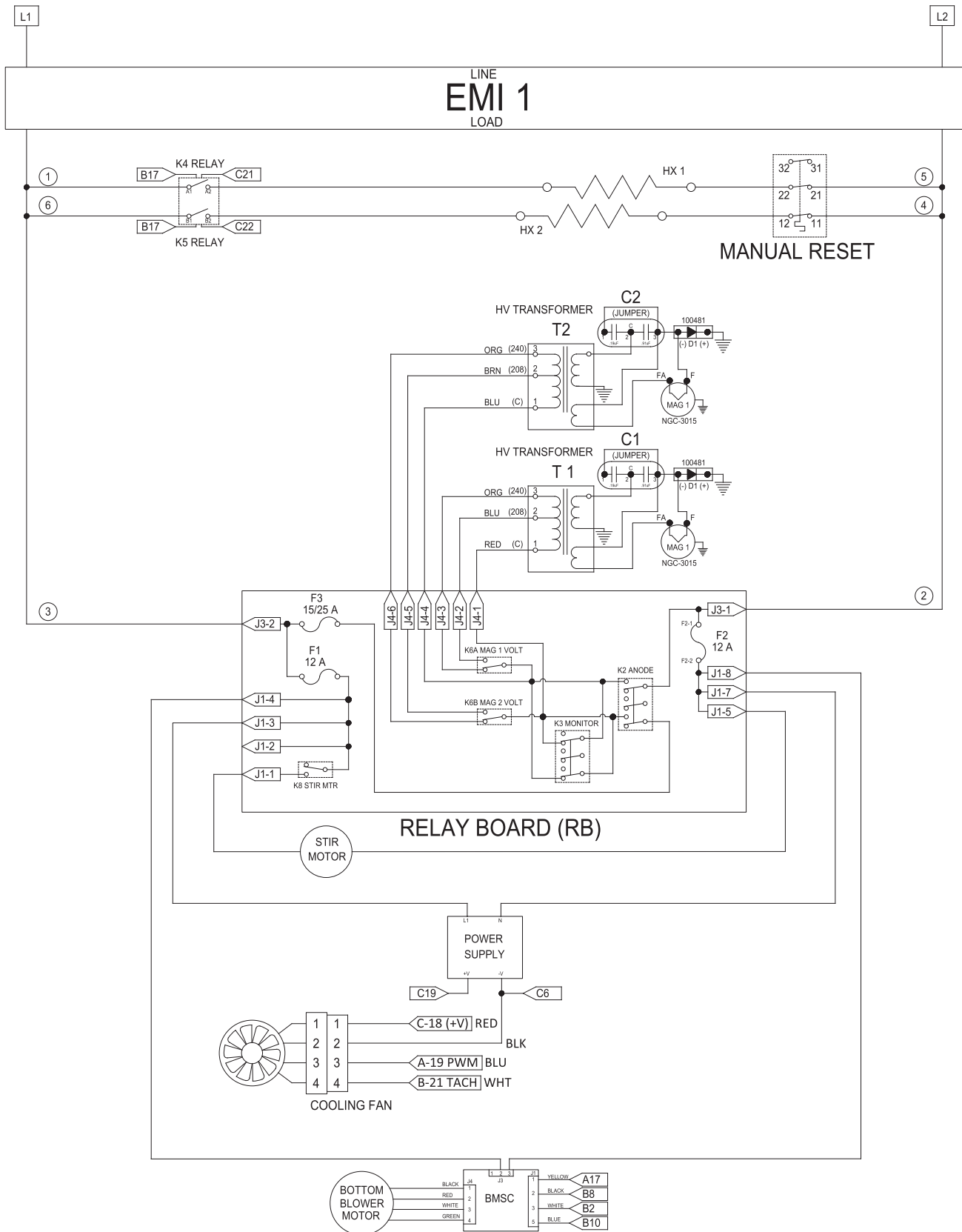

Figure 88: Ladder Diagram - Single Phase

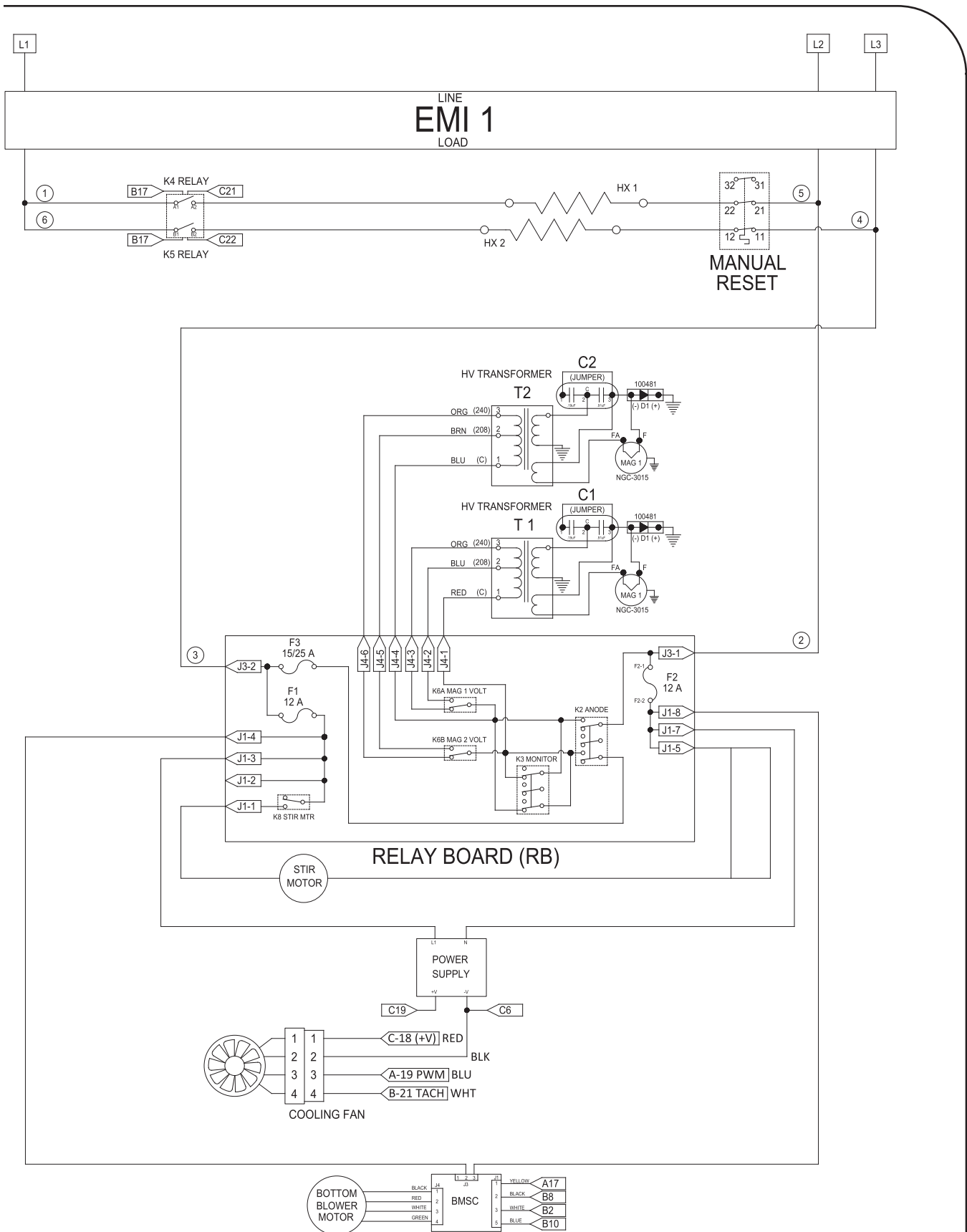

Figure 89: Ladder Diagram - Three Phase Delta

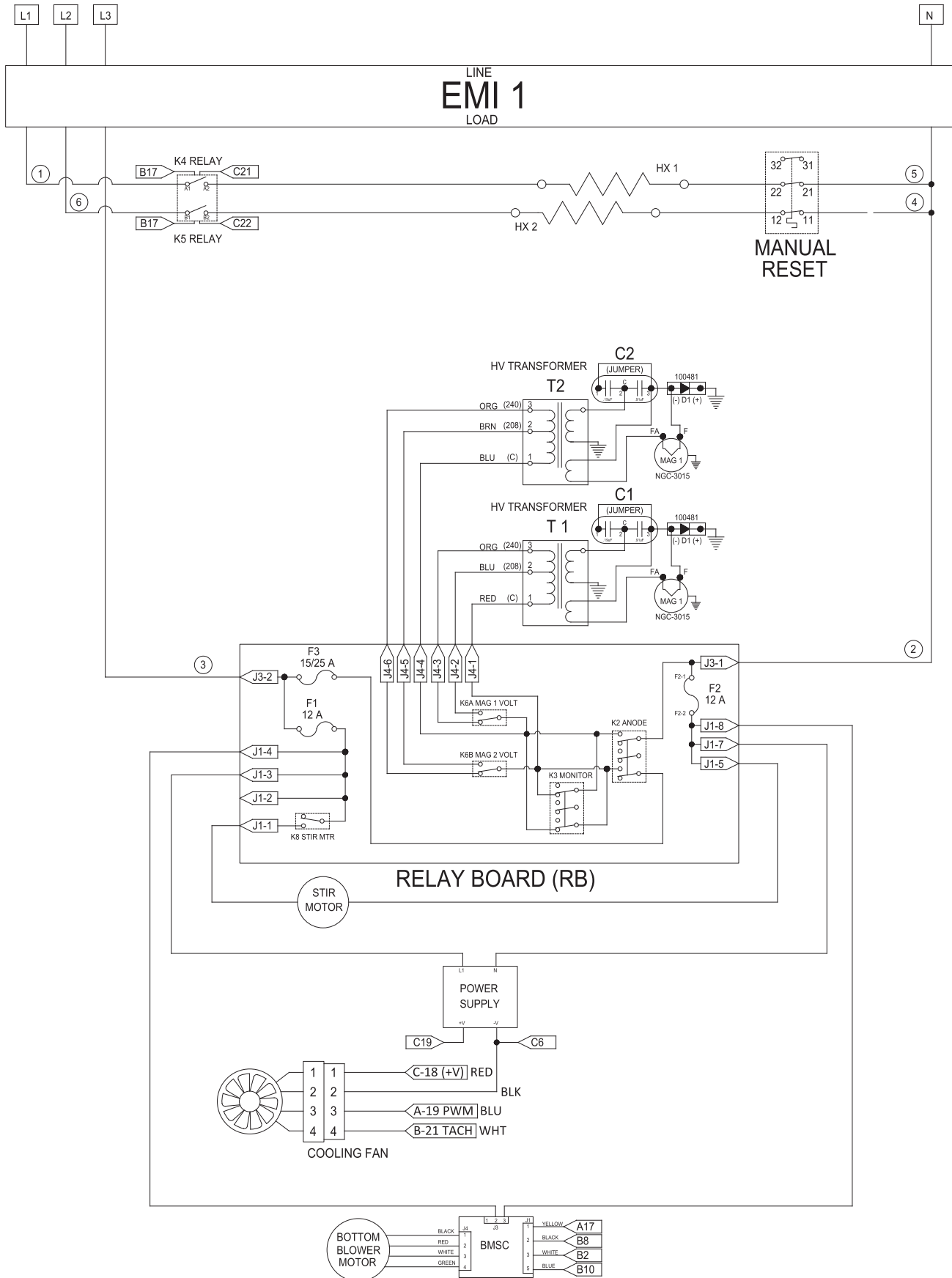

Figure 90: Ladder Diagram - Three Phase Wye

Appendix - Oven Components

Replacing Oven Components

This appendix provides illustrations for removing serviceable items, as well as the item numbers and descriptions for those items. It also includes the item numbers and descriptions for the fasteners used to secure each component to the oven chassis.

The appendix is divided into the following sections:

- Exterior and Cavity Components (pages A-2 and A-3)
- Door Components (pages A-4 and A-5)
- Left/Blower Side (pages A-6 and A-7)
- Right/Heater Side and Transformers (pages A-8 and A-9)
- Top of Oven and Back Panel (pages A-10 and A-11)
- Display Housing (pages A-12 and A-13)
- Power Cords and Wire Harnesses (page A-14)

If you have any questions that are not addressed in this manual or appendix, please contact TurboChef Customer Service at 800.90TURBO or +1 214.379.6000.

Exterior and Cavity Components (Figures A-1 and A-2)

⚠ CAUTION: Before removing/installing any component, make sure it is disconnected from the wire harness (where applicable).

NOTE: Fasteners listed are required for installing component to oven.

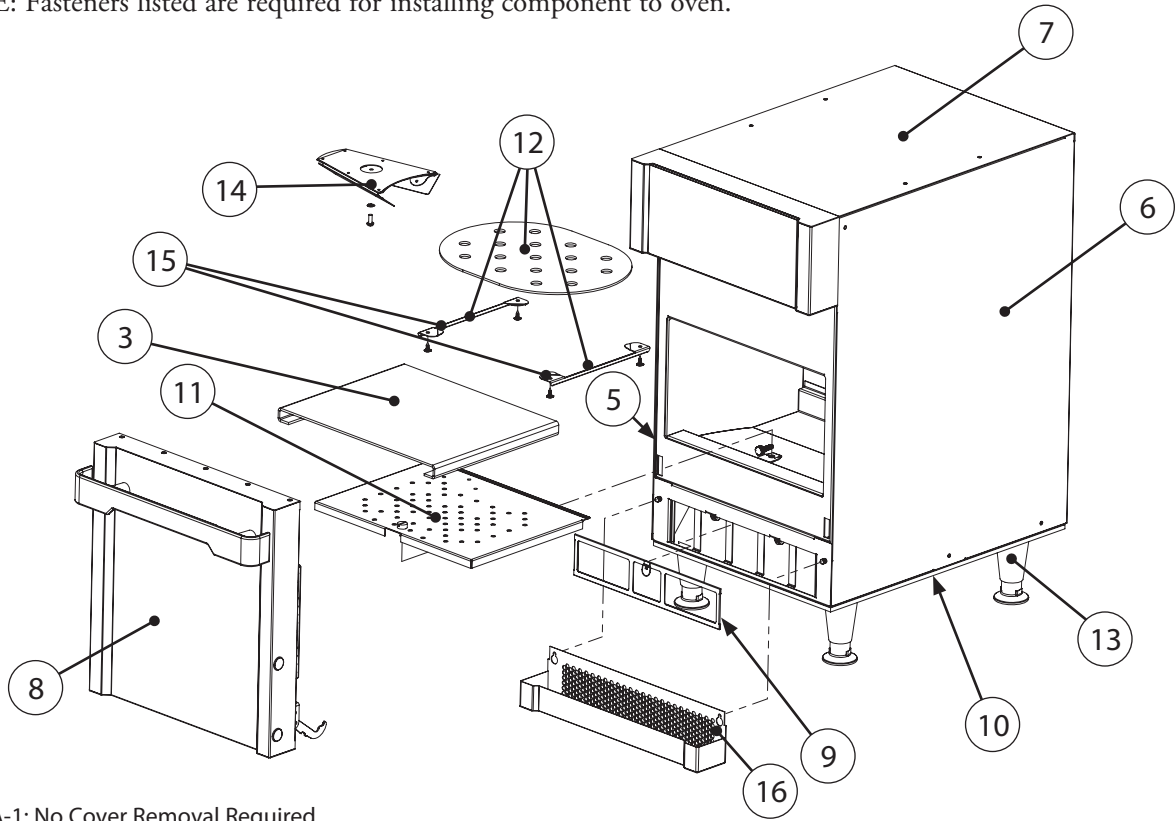

Figure A-1: No Cover Removal Required

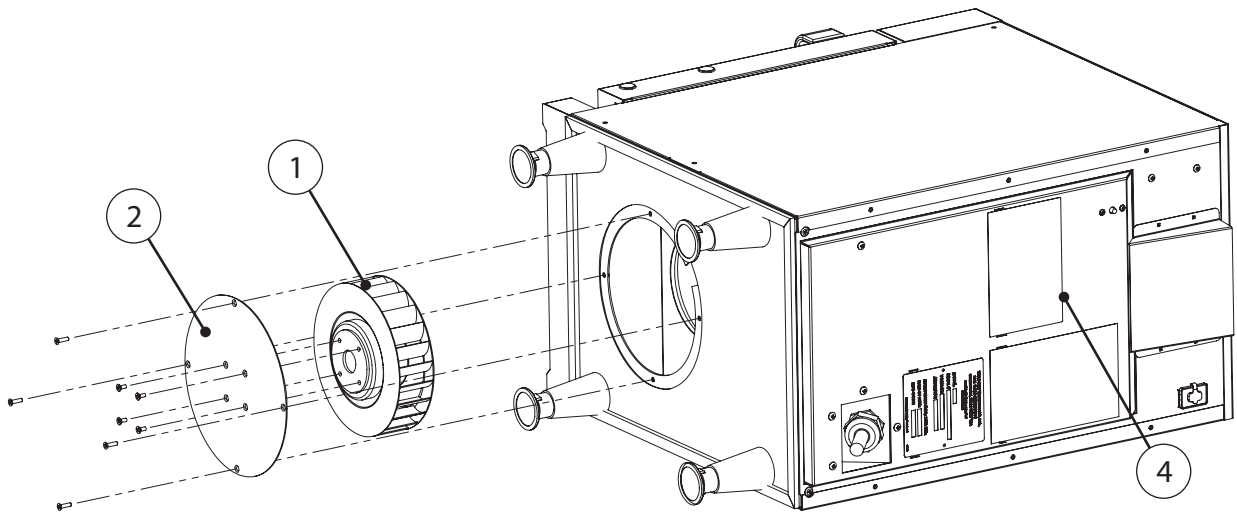

Figure A-2: Bottom Fan Removal

Figure #	Item Description	Item Part Number	Fastener Description	Fastener Part Number(s)
1	Cooling Fan, Base	105408	SCREW, M4 X 8MM LG, PFH 90 DEG, STEEL-ZINC	101735 (qty 4)
2	Cooling Fan, Plate	ECS-9817	SCREW, #8-32 X 5/8, PFH, 100 DEG, SS	102811 (qty 4)
3	Cook Plate	i1-9808	None	None
4	Cover, Back	ECS-9788*	Screw # 8 X 3/8 Phil. Mod. Truss B 410 Stainless	101682 (qty 4)
5	Cover, Left (available in multiple colors)	ECS-9802*	Screw # 8 X 3/8 Phil. Mod. Truss B 410 Stainless	101682 (qty 3)
6	Cover, Right (available in multiple colors)	ECS-9801*	Screw # 8 X 3/8 Phil. Mod. Truss B 410 Stainless	101682 (qty 3)
7	Cover, Top (available in multiple colors)	ECS-9800*	Screw, #8-16, Sheet Metal, Type A, Stainless, Torx Security, Pan Head Screw # 8 X 3/8 Phil. Mod. Truss B 410 Stainless	102752 (qty 2) 101682 (qty 4)
8	Door Assembly (available in multiple colors)	ECS-3201*	Included	Included
9	Filter	ECS-9806	None	None
10	Gasket, Base	ECS-9334	None	None
11	Jetplate, Bottom	ECS-9160	Fast Lead Screw Retainer (12-6-1) Screw, Thumb, W HD, #1/4-20 x 3/8", SS	102817 101772
12	Kit, Jetplate, Top	i1-3219	Screw, #8 X 1/2 Phillips, Truss, Type 17, Serrated, 410 SS	101688 (qty 4)
13	Leg, 4", Black	100785 (qty 4)	None	None
14	Microwave Stirrer Kit	i1-3212	included	Included
15	Rail, Support, Top Jetplate	i1-9179-2 (x2) Included in the i1-3219 kit	Screw, #8 X 1/2 Phillips, Truss, Type 17, Serrated, 410 SS	101688 (qty 2 per)
16	Tray, Front (available in multiple colors)	ECS-9573*	None	None

*The ECO ST oven is available in 6 standard colors (Stainless, Black, Red, Green White, and Blue) and can also be purchased as a custom color. To differentiate painted parts, TurboChef adds a four character color code to the base part number.

For example: A stainless top cover is [ECS-9800](#), if a black top cover is needed, the part number would be [ECS-9800-T013](#). If a green top cover is needed, the part number would be [ECS-9800-T016](#).

Use the list below to determine the proper color codes.

- Stainless: No color code, use the base part number
- Black: -T013
- Red: -T014
- Green: -T016
- White: -T017
- Blue: -T018
- Any other color: Contact factory for assistance

Door Components (Figures A-3 and A-4)

⚠ CAUTION: Before removing/installing any component, make sure it is disconnected from the wire harness (where applicable).

NOTE: Fasteners listed are required for installing component to oven.

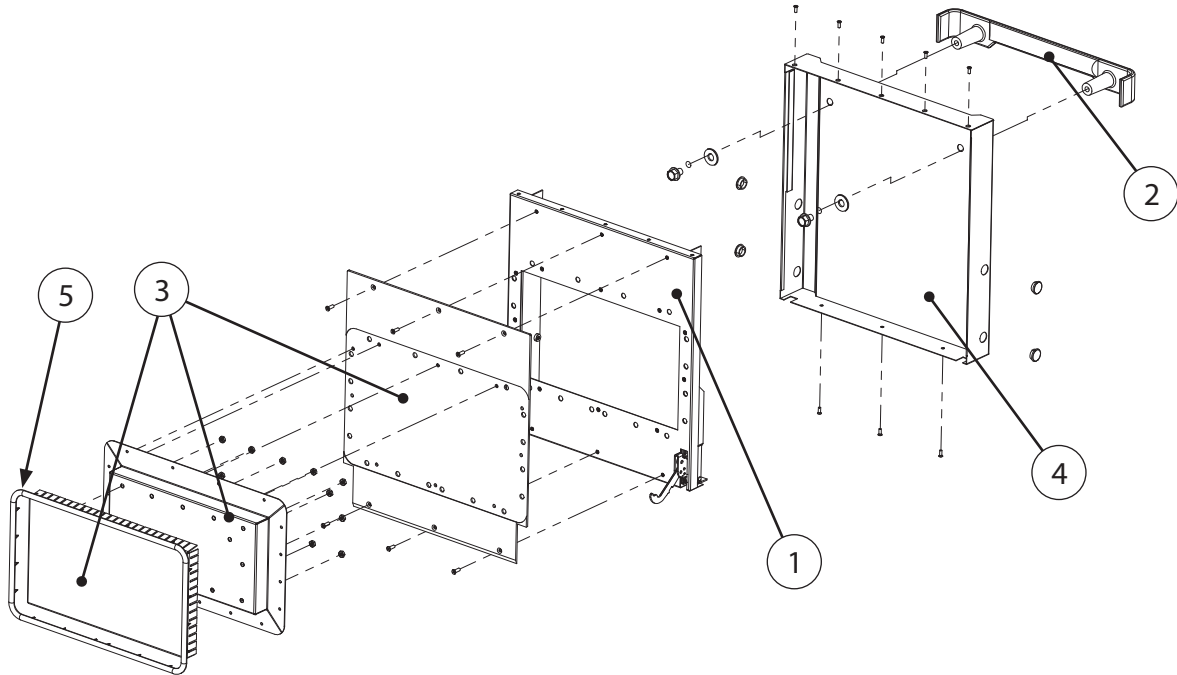

Figure A-3: Door, Exploded View

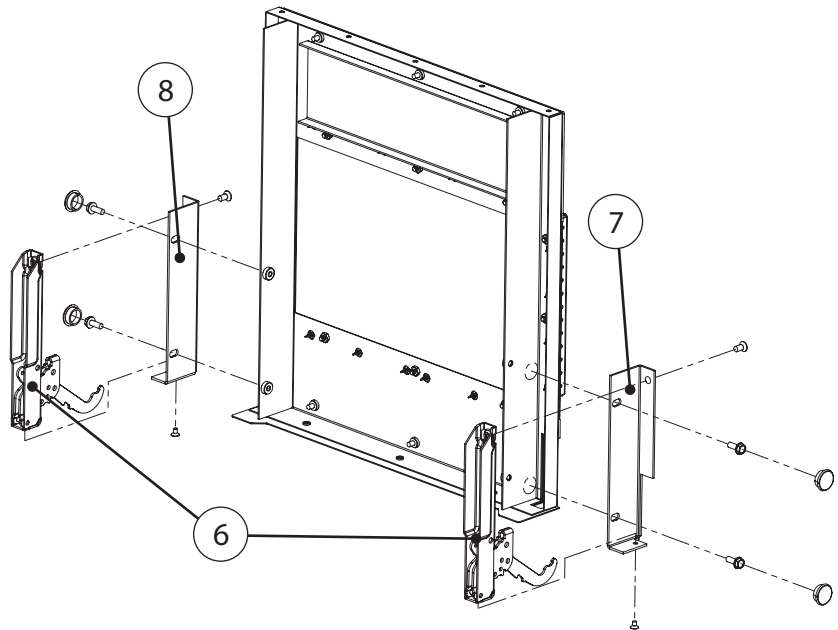

Figure A-4: Door, Hinge Mounting

Figure #	Item Description	Item Part Number	Fastener Description	Fastener Part Number(s)
1	Door Cover, Inner	ECS-9805	SCREW 8-32 X 3/8 PFLH, 100 DEG, SS	102809 (qty 14)
2	Door Handle (available in multiple colors)	ECO-9460* (See Page A-3, only available in Black and Stainless)	Screw, 3/8-16 x .75, Serr Hex WSHR HD, PL STL WASHER, 3/8 FLAT, SS	101380 (qty 2) 102210 (qty 2)
3	Door Shunt Plate Kit	ECS-3210	Included	Included
4	Door Skin (available in multiple colors)	ECS-9109*	SCREW 8-32 X 3/8 PFLH, 100 DEG, SS	102809 (qty 8)
5	Gasket, Door	ECS-9783	None	None
6	Hinge	105297 (qty 2)	SCREW M5 X 8MM PFLH 100 SCREW, M3.5 X 6MM PFLH SS	101443 (qty 1 per hinge) 102809 (qty 1 per hinge)
7	Hinge Bracket, Left	ECS-9777	SCREW, #10-32 X 1/2", HEX, SERR, ZINC	101373 (qty 2)
8	Hinge Bracket, Right	ECS-9776	SCREW, #10-32 X 1/2", HEX, SERR, ZINC	101373 (qty 2)

Left/Blower Side (Figure A-5)

! DANGER: Before replacing any oven component, ensure the oven is removed from any power source. Replacing a component while the oven is plugged in can result in serious injury or death

! CAUTION: Be careful to not tear the insulation when servicing components. Always reinstall the insulation properly before reinstalling the outer shell.

NOTE: Fasteners listed are required for installing component to oven.

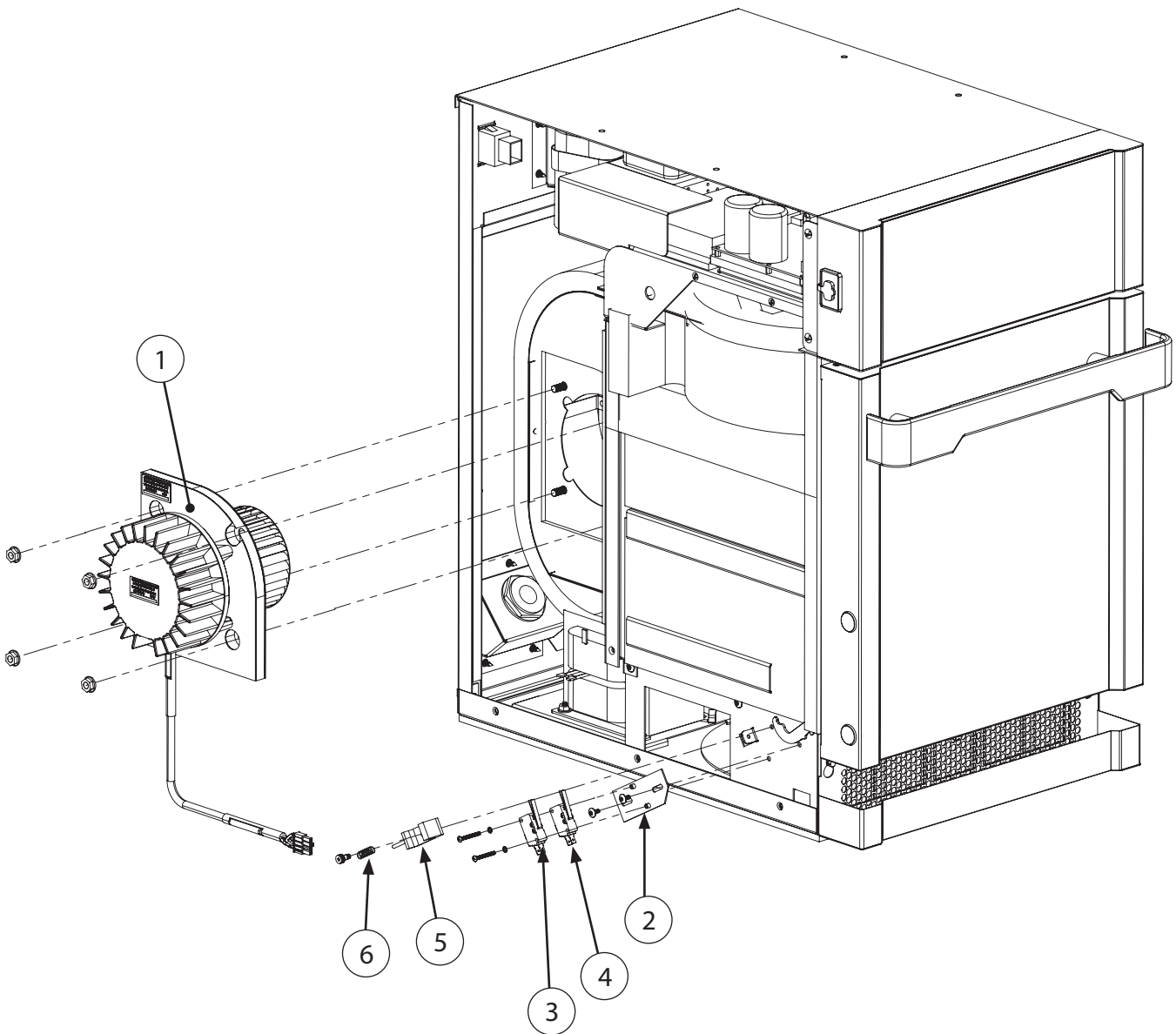

Figure A-5: Left/Blower Side of Oven

Figure #	Item Description	Item Part Number	Fastener Description	Fastener Part Number(s)
1	Blower Motor	ECS-9823	NUT, 1/4-20, SERRATED HEX FLANGE, ZINC	100906 (qty 4)
2	Bracket, Door Switch, Left	ECS-9808	SCREW #8-32 X 3/8, PPHD, SEMS, SS	102921 (qty 2)
3	Door Switch, Primary	102013	SCREW, PPH, SS, 4-40 UNC X 1" LG. WASHER, LOCK, INT TOOTH #4	101556 (qty 2) 102300 (qty 2)
4	Door Switch, Secondary	102013	None	None
5	Plunger, Door Switch	ECS-9445	BOLT, SHOULDER #8-32 X .188 SHDR X 3/8	105304
6	Spring, Door Switch	CT-104040	None	None

Right/Heater Side and Transformers (Figures A-6 and A-7)

! DANGER: Before replacing any oven component, ensure the oven is removed from any power source. Replacing a component while the oven is plugged in can result in serious injury or death

! CAUTION: Be careful to not tear the insulation when servicing components. Always reinstall the insulation properly before reinstalling the outer shell.

NOTE: Fasteners listed are required for installing component to oven.

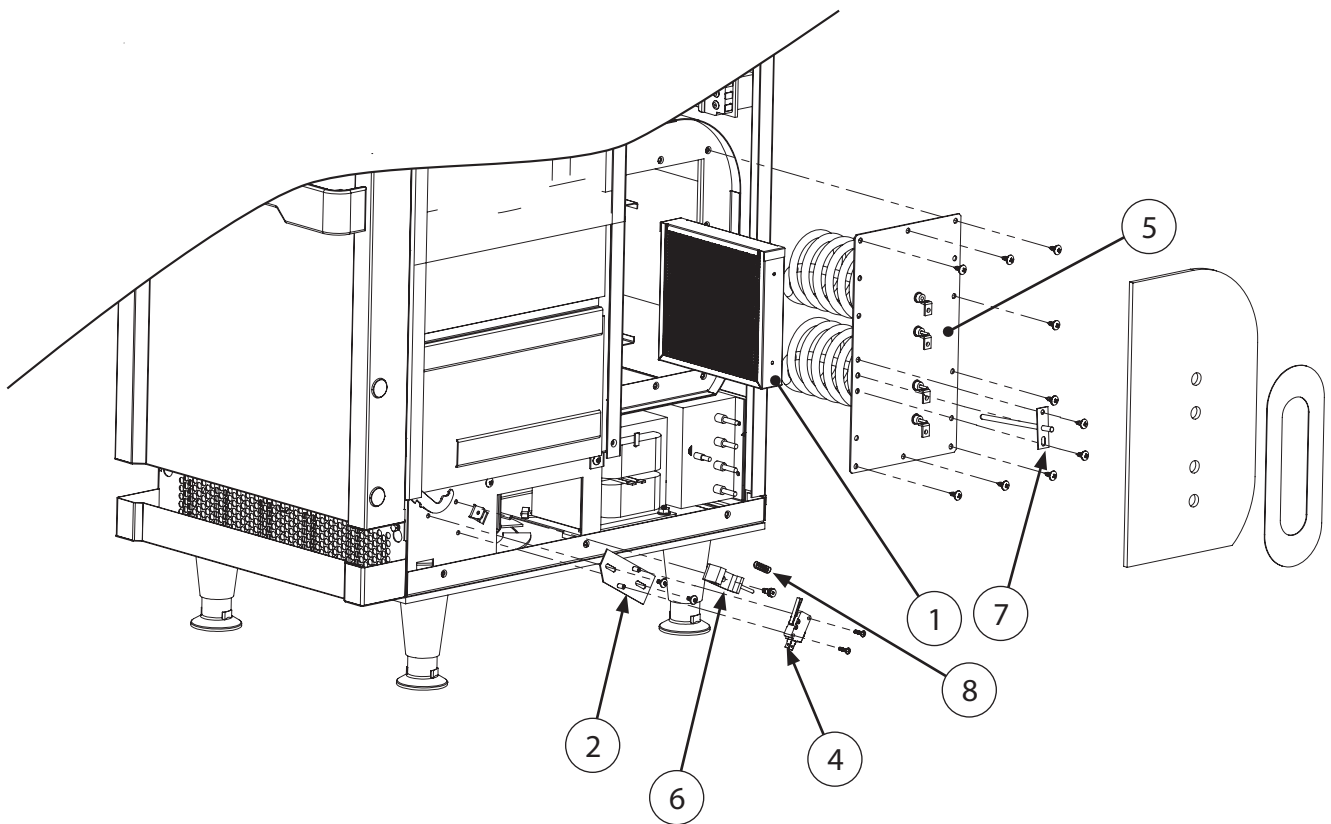

Figure A-6: Right/Heater Side of Oven

Figure #	Item Description	Item Part Number	Fastener Description	Fastener Part Number(s)
1	Catalyst	ECO-9066	None	None
2	Bracket, Door Switch, Right	ECS-9809	SCREW #8-32 X 3/8, PPHD, SEMS, SS	102921 (qty 2)
3	Bracket, Transformer	ECO-9024 (qty 2)	Screw, #8 X 1/2 Phillips, Truss, Type 17, Serrated, 410 SS	101688 (qty 2 per)
4	Door Switch, Monitor	102013	SCREW, #4-40 x 1/2 SEMS, PPHD, CRES	105404 (qty 2)
5	Heater, Helical	ECS-9566	Screw, #8 X 1/2 Phillips, Truss, Type 17, Serrated, 410 SS	101688 (qty 10)
6	Plunger, Door Switch	ECS-9445	BOLT, SHOULDER #8-32 X .188 SHDR X 3/8	105304
7	RTD	ECS-9818	Screw, #8 X 1/2 Phillips, Truss, Type 17, Serrated, 410 SS	101688 (qty 2)
8	Spring, Door Switch	CT-104040	None	None
9	Thermostat, 280°F Open on Rise	104167 (qty 2)	None	None
10	Transformer, HV	105258 (qty 2)	See Bracket, Transformer	None

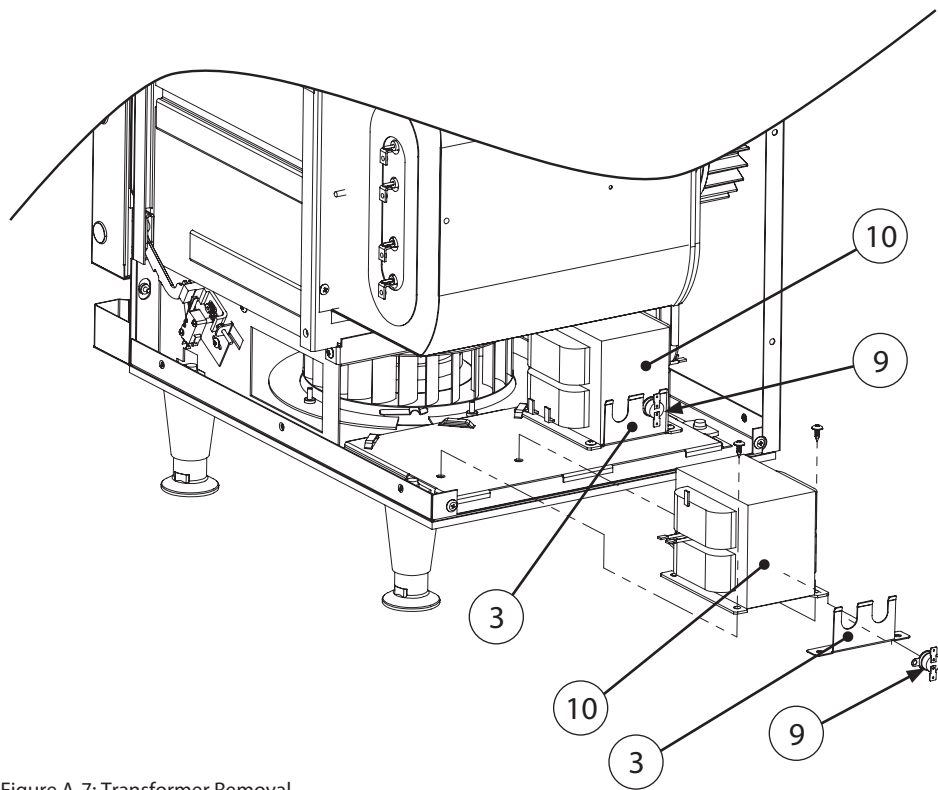

Figure A-7: Transformer Removal

Top of Oven and Back Panel (Figures A-8 through A-10)

⚠ DANGER: Before replacing any oven component, ensure the oven is removed from any power source. Replacing a component while the oven is plugged in can result in serious injury or death

⚠ CAUTION: Be careful to not tear the insulation when servicing components. Always reinstall the insulation properly before reinstalling the outer shell.

NOTE: Fasteners listed are required for installing component to oven.

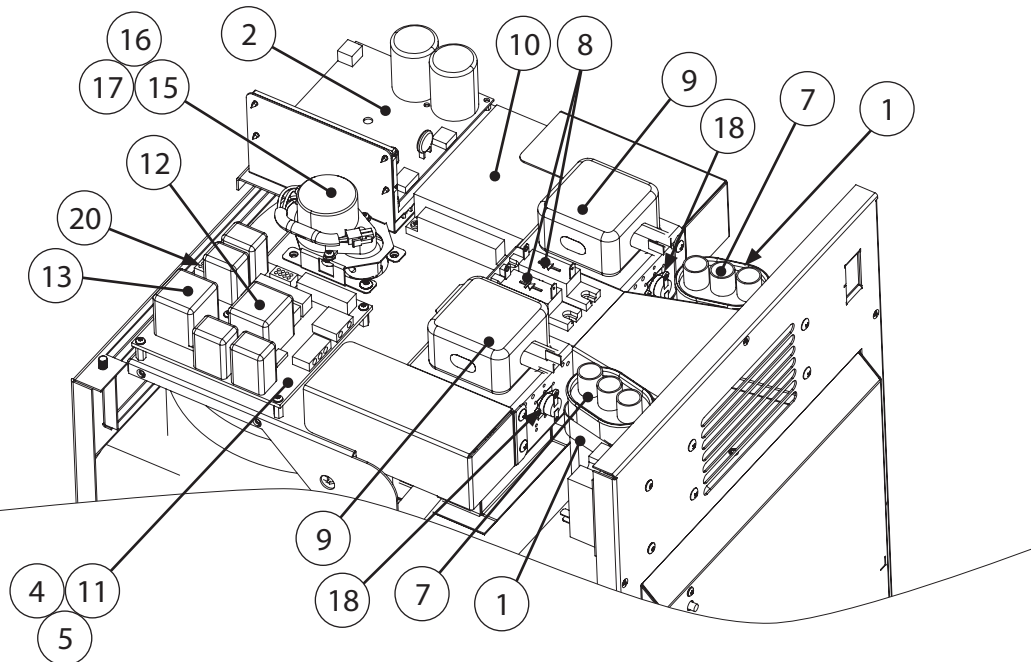

Figure A-8: Top Electrical Compartment

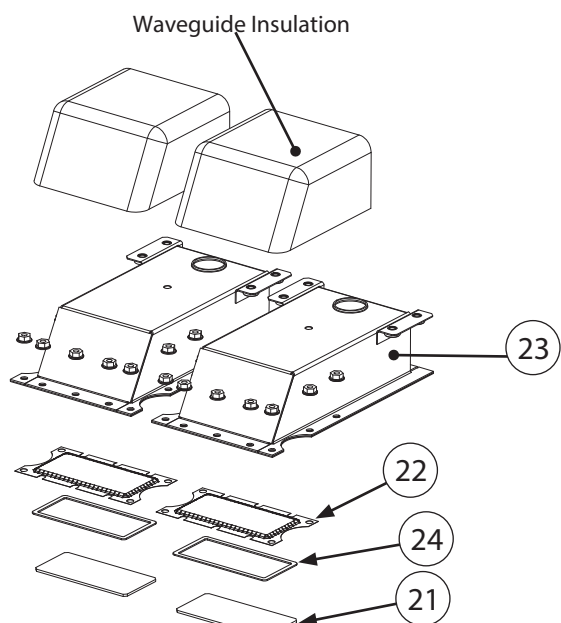

Figure A-9: Waveguide Detail

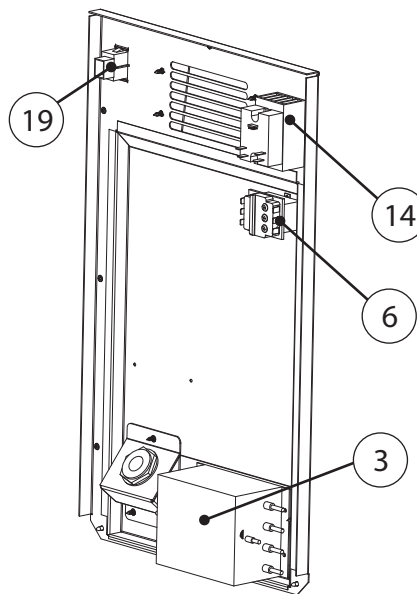

Figure A-10: Back Panel

Figure #	Item Description	Item Part Number	Fastener Description	Fastener Part Number(s)
1	Clamp, Capacitor	100131 (qty 2)	Screw, #8 X 1/2 Phillips, Truss, Type 17, Serrated, 410 SS	101688
2	Blower Motor Controller	CON-7013	Screw, #8 X 1/2 Phillips, Truss, Type 17, Serrated, 410 SS	101688 (qty 4)
3	EMI Filter	100548	NUT #6-32 KEPS EXTERNAL TOOTH SS	102961 (qty 2)
4	Fuse 12 Amp	100592 (qty 2)	None	None
5	Fuse 25 Amp	100604	None	None
6	High Limit	102075	SCREW M 4 x 6 PPH SQ CO SEMS, ZINC	101672 (qty 2)
7	HV Capacitor	100217 (qty 2)	None	None
8	HV Diode	100481 (qty 2)	SCREW #8 x 1/2	101689 (qty 2)
9	Magnetron	NGC-3015 (qty 2)	SCREW, SEMS, #8-32 X 5/8 LG, PPHD, CRES	102926 (qty 4)
10	Power Supply	NGC-3069	Included in kit	Included in kit
11	Relay Board	CON-7200	SCREW, 6-32 X 3/8 PAN PHIL M/S 18-8 SEMS INT LW	102911 (qty 5)
12	Relay, K2 (Anode)	105160	Cable Tie, 15.8", 18 LB Tensile Strength	105320
13	Relay, K3 (Monitor)	105160	Cable Tie, 15.8", 18 LB Tensile Strength	105320
14	Solid State Relay (Heaters)	101286	Screw, #8 X 1/2 Phillips, Truss, Type 17, Serrated, 410 SS	101688 (qty 2)
15	Stirrer Coupling Hub	104132	Set Screw (Provided)	None
16	Stirrer Motor	105108	SCREW, 6-32 X 3/8 PAN PHIL M/S 18-8 SEMS INT LW	102910 (qty 2)
17	Stirrer Shaft	i1-3214	Included with kit	Included
18	Thermostat, Magnetron, 270°F Open on Rise	104228 (qty 2)	SCREW, #6 X 3/8, PPH, DRILL POINT, ZINC	101684 (qty 2)
19	USB Port	100419	None	None
20	Voltage Module	CON-7136	None	None
21	Waveguide Cover	i1-9701 (qty 2)	None	None
22	Waveguide Gasket	i1-9331 (qty 2)	NUT, #10-32, HEX, ZINC, SERRATED FLANGE	100913 (qty 9)
23	Waveguide, Insulated	ECS-9153 (qty 2)	None	None
24	Waveguide Seal	i1-9486 (qty 2)	None	None

Display Housing (Figure A-11)

! DANGER: Before replacing any oven component, ensure the oven is removed from any power source. Replacing a component while the oven is plugged in can result in serious injury or death

! CAUTION: Be careful to not tear the insulation when servicing components. Always reinstall the insulation properly before reinstalling the outer shell.

NOTE: Fasteners listed are required for installing component to oven.

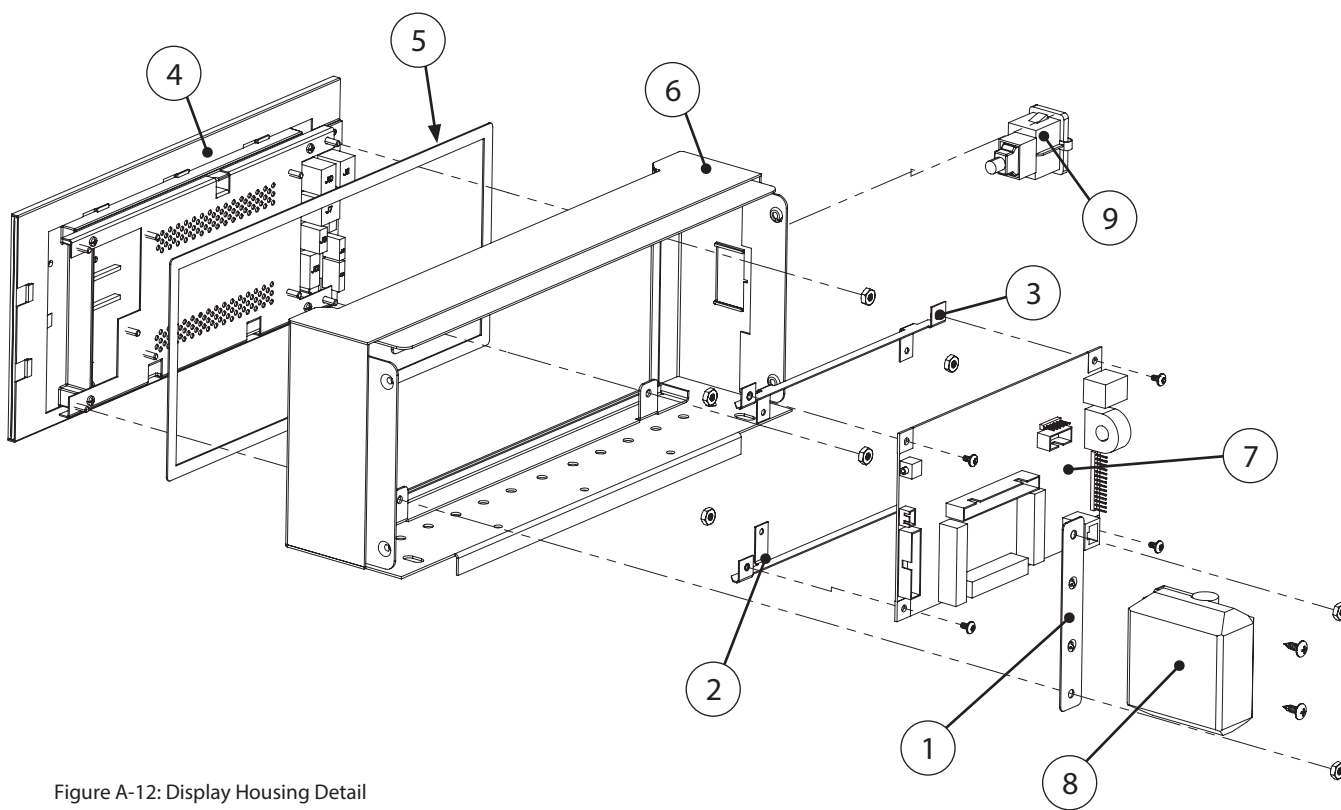



Figure A-12: Display Housing Detail

Figure #	Item Description	Item Part Number	Fastener Description	Fastener Part Number(s)
1	Bracket, Speaker	ECS-9775	NUT #8-32 SERR HEX FLNG ZINC	100901 (qty 2)
2	Bracket, Support, Bottom	i1-9609	NUT #8-32 SERR HEX FLNG ZINC	100901 (qty 2)
3	Bracket, Support, Top	i1-9608	NUT #8-32 SERR HEX FLNG ZINC	100901 (qty 2)
4	Display with Glass	CON-7132-2	NUT #8-32 SERR HEX FLNG ZINC	100901 (qty 4)
5	Gasket, Touch Display	ECO-9585	None	None
6	Housing, Display (available in multiple colors)	ECS-9584* (See page A-3)	SCREW, 1/4-20X3/8" LG HEX SERRATED FLANGE	102948 (qty 2)
7	SAGE Control Board	CON-7078	SCREW,#6-32X1/4,SIM,INT TOOTH, PPHD	102910 (qty 4)
8	Speaker	104214	Screw, #8 X 1/2 Phillips, Truss, Type 17, Serrated, 410 SS	101688 (qty 2)
9	USB Port	100419	None	None
Not Shown	Firmware, SAGE	CON-7099	None	None
Not Shown	Firmware, Touch	CON-7134	None	None
Not Shown	SD Card, Programmed	Contact Factory	None	None
Not Shown	WiFi Module	105254	None	None

Power Cords and Wire Harnesses

 **DANGER:** Before replacing any oven component, ensure the oven is removed from any power source. Replacing a component while the oven is plugged in can result in serious injury or death

 **CAUTION:** Be careful to not tear the insulation when servicing components. Always reinstall the insulation properly before reinstalling the outer shell.

NOTE: Power cord and wire harness part numbers may change. Contact factory for assistance.

Power Cord Part Numbers

Oven Model/Type	Power Cord Part Number
US	100187
EU	Contact Factory
UK	Contact Factory
AK	Contact Factory
JK	Contact Factory
BK	Contact Factory
SK	Contact Factory
KA	Contact Factory

Wire Harness Part Numbers

Part Number	Description
ECS-9060	HARNESS, HIGH VOLTAGE
ECS-9061	HARNESS, LINE VOLTAGE
ECS-9062	HARNESS, HEATER, SINGLE PHASE
ECS-9063	HARNESS, LOW VOLTAGE
ECS-9064	HARNESS, BLOWER AND POWER SUPPLY
103193	CABLE, USB, 12"
105415	CABLE, USB, 24"

This page intentionally blank.

For service or information:

WITHIN NORTH AMERICA CALL

Customer Support *at* 800.90TURBO

OUTSIDE NORTH AMERICA CALL

+1 214.379.6000 or Your Authorized Distributor



Part Number: ECS-1002 / Revision A / September 2019
Country Code: NA/EU

Global Operations

2801 Trade Center Drive
Carrollton, Texas 75007 USA
+1 214.379.6000 PHONE
+1 214.379.6073 FAX

Customer Support:

800.90TURBO
+1 214.379.6000
turbochef.com