

HhB and HhB 2 Ventless Submittal Information

Spec Sheet	1.1
UL® Ventless Label.....	2.1
UL® Listing.....	3.1
UL® KNLZ Explained.....	4.1
City of Los Angeles LAPC and LAMC Approval.....	5.1
HHB UL® Certification Emissions Test	6.1
Grease Emissions of Grease-Laden Products	7.1
Emissions by Product.....	8.1
HHB ASTM Energy Test Result	9.1
HHB Energy Usage Estimate.....	10.1
Oven Surface Temperatures.....	11.1
TurboChef Installation Recommendations.....	12.1



THE HIGH h BATCH 2™



HIGH h BATCH 2™

Project _____

Item No. _____

Quantity _____

EXTERIOR CONSTRUCTION

- Stainless steel front, top, back, and powder-coated sides
- 4" (102 mm) matte black legs
- Ergonomic, cool to touch powder-coated door handle

INTERIOR CONSTRUCTION

- 304 stainless steel interior
- Watertight construction
- Interchangeable jetplates for customized cooking results

STANDARD FEATURES

- Integral recirculating catalytic converter for UL® 710B (KNLZ) listed ventless operation
- Variable-speed High h recirculating air impingement system
- Oscillating rack for high heat transfer without spotting
- Half-sheet pan/16-inch pizza capacity
- Smart Voltage Sensor Technology* (N.A. only)
- Stackable design (requires stacking kit)
- Smart menu system capable of storing up to 72 recipes
- Built-in self diagnostics for monitoring oven components and performance
- Includes plug and cord (6 ft. nominal)
- Smart card compatible
- Warranty – 1 year parts and labor

PERFORMANCE

- Heat transfer rates (h) are 3X-4X typical convection oven
- Heat transfer rates (h) are 2X typical conveyor oven
- The High h Batch 2 offers high quality, full baking capabilities up to 5X faster than traditional cooking equipment, achieving conveyor-type results in a compact size

VENTILATION

- UL 710B (KNLZ) listed for ventless operation.†
- EPA 202 test (8 hr):
 - Product / Results
 - Fries, Chicken Breasts, Chicken Wings, and Ground Beef Patties / 0.10 mg/m³
 - Pepperoni Pizzas / 0.40 mg/m³
 - Ventless Requirement: <5.00 mg/m³
- Internal catalytic filtration to limit smoke, grease, and odor emissions.

COMES WITH STANDARD ACCESSORIES

- 1 Aluminum Paddle (NGC-1478)
- 1 Bottle Oven Cleaner (103180)
- 1 Bottle Oven Guard (103181)
- 2 Trigger Sprayers (103182)
- 1 14x16 Non-stick Screen (100018)

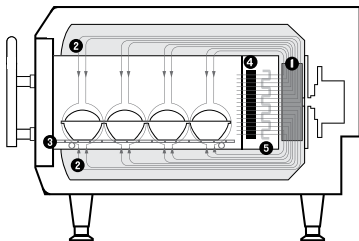
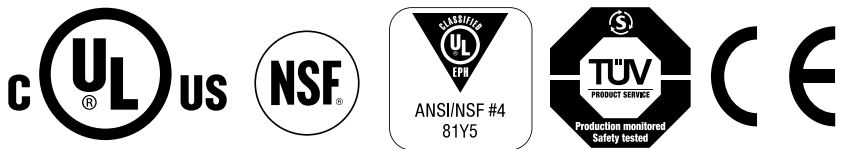

1. Blower Motor
2. Impinged Air
3. Oscillating Rack
4. Catalytic Converter
5. Impingement Heater

This product conforms to the ventilation recommendations set forth by NFPA96 using EPA202 test method.



* Smart Voltage Sensor Technology does not compensate for lack of or over voltage situations. It is the responsibility of the owner to supply voltage to the unit according to the specifications on the back of this sheet.



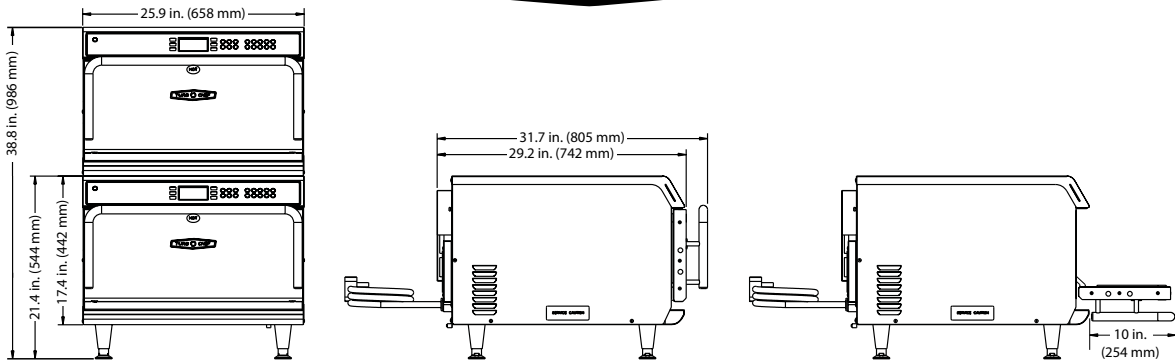

† Ventless certification is for all food items except for foods classified as "fatty raw proteins." Such foods include bone-in, skin-on chicken, raw hamburger meat, raw bacon, raw sausage, steaks, etc. If cooking these types of foods, consult local HVAC codes and authorities to ensure compliance with ventilation requirements.

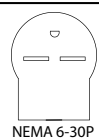
Ultimate ventless allowance is dependent upon AHJ approval, as some jurisdictions may not recognize UL certification or application. If you have questions regarding ventless certifications or local codes please email ventless.help@turbochef.com

TurboChef reserves the right to make substitutions of components or change specifications without prior notice.



DIMENSIONS		
Single Units		
Height	21.4"	544 mm
Width	25.9"	658 mm
Depth	29.2"	742 mm
with handle	31.7"	805 mm
Weight	157 lb.	71 kg
Stacked Units (Stacking Kit Required)		
Height	38.8"	986 mm
top unit with legs	42.8"	1087 mm
Width	25.9"	658 mm
Depth	29.2"	742 mm
with handle	31.7"	805 mm
Weight	314 lb.	142 kg
Cook Chamber		
Height	8"	203 mm
Width	18.75"	476 mm
Depth	16.75"	425 mm
Volume	1.45 cu. ft.	41.1 liters
Wall Clearance (Oven not intended for built-in installation)		
Top	2"	51 mm
Sides	2"	51 mm
ELECTRICAL SPECIFICATIONS		
UNITED STATES		
HHB2 (HHB-8603-1)		
Phase	1 Phase	 NEMA 6-30P
Voltage	208/240 VAC	
Frequency	50/60 Hz	
Current / Max Circuit Requirement	24 / 30 amp	
Cord	10 gauge, 3 wire, 5 ft., SOOW	
Max Input	5000 watts	
CANADA		
HHB2C (HHB-8603-1C)		
Phase	1 Phase	 NEMA 6-50P
Voltage	208/240 VAC	
Frequency	50/60 Hz	
Current / Max Circuit Requirement	24 / 50 amp	
Cord	10 gauge, 3 wire, 5 ft., SOOW	
Max Input	5000 watts	

LATIN AMERICA		
HHB2LA (HHB-8603-1K-2073)		
Phase	1 Phase	 NEMA 6-30P
Voltage	230 VAC	
Frequency	50/60 Hz	
Current / Max Circuit Requirement	24 / 32 amp	
Cord	10 gauge, 3 wire, 5 ft., SOOW	
Max Input	5000 watts	
EUROPE/ASIA-PACIFIC		
HHB2EW (HHB-8603-1W)		
Phase	3 Phase	 IEC 309 5-pin, 16 amp
Voltage	400 VAC	
Frequency	50/60 Hz	
Current / Max Circuit Requirement	10 / 16 amp	
Cord	HO7RN-F, 5 wire	
Max Input	5000 watts	
HHB2ED (HHB-8603-1D)		
Phase	3 Phase	 IEC 309 4-pin, 20 amp
Voltage	230 VAC	
Frequency	50/60 Hz	
Current / Max Circuit Requirement	14 / 20 amp	
Cord	HO7RN-F, 4 wire	
Max Input	5000 watts	
HHB2UK (HHB-8603-1K)		
Phase	1 Phase	 IEC 309 3-pin, 32 amp
Voltage	230 VAC	
Frequency	50/60 Hz	
Current / Max Circuit Requirement	24 / 32 amp	
Cord	HO7RN-F, 3 wire	
Max Input	5000 watts	
SHIPPING INFORMATION		
U.S.: All ovens shipped within the U.S. are packaged in a double-wall corrugated box banded to a wooden skid.		
International: All International ovens shipped via Air or Less than Container Loads are packaged in wooden crates.		
Box size: 37" x 32" x 28" (940 mm x 813 mm x 711 mm)		
Crate size: 40" x 36" x 35" (1016 mm x 914 mm x 889 mm)		
Item class: 85 NMFC #26770 HS code 8419.81		
Approximate boxed weight: 210 lb. (95 kg)		
Approximate crated weight: 285 lb. (129 kg)		
Minimum entry clearance required for box: 28.5" (724 mm)		
Minimum entry clearance required for crate: 35.5" (902 mm)		

TurboChef Global Operations
 4240 International Pkwy, Suite 105 / Carrollton, Texas 75007 USA
 US: 800.90TURBO (800.908.8726) / International: +1 214.379.6000
 Fax: +1 214.379.6073 / turbochef.com

TurboChef reserves the right to make substitutions of components or change specifications without prior notice.

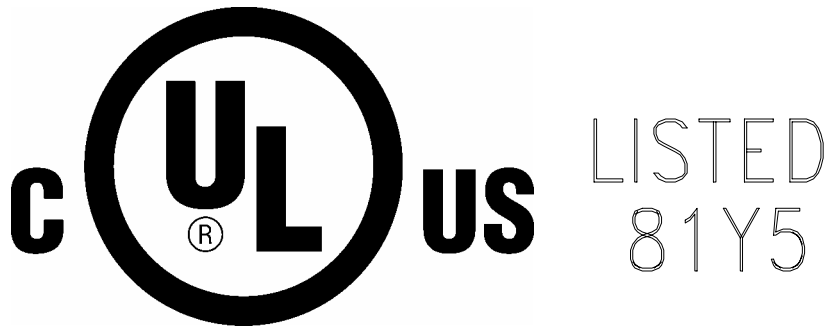

Commercial Microwave/Convection Oven
with Integral Systems for Limiting
the Emissions of Grease Laden Air

This Product Conforms to the Ventilation Recommendations
Set Forth by NFPA96 Using EPA202 Test Method

 Underwriters Laboratories Inc.

KNLZ.E151487

Commercial, with Integral Systems for Limiting the Emission of Grease-laden Air

[Page Bottom](#)[Print-friendly version](#)[Questions?](#)[Previous Page](#)

Commercial, with Integral Systems for Limiting the Emission of Grease-laden Air

[See General Information for Commercial, with Integral Systems for Limiting the Emission of Grease-laden Air](#)

TURBOCHEF INC
 SUITE 128
 10500 METRIC DR
 DALLAS, TX 75243 USA

E151487

Commercial microwave/convection ovens, Models C3/C, HHB, NGC.

[Last Updated](#) on 2005-06-07

[Page Top](#)[Notice of Disclaimer](#)[Questions?](#)[Previous Page](#)[UL Listed and Classified Products](#)[UL Recognized Components](#)[Products Certified for Canada](#)

This page and all contents are Copyright © 2005 by Underwriters Laboratories Inc.®

The appearance of a company's name or product in this database does not in itself assure that products so identified have been manufactured under UL's Follow-Up Service. Only those products bearing the UL Mark should be considered to be Listed and covered under UL's Follow-Up Service. Always look for the Mark on the product.

UL permits the reproduction of the material contained in the Online Certification Directory subject to the following conditions: 1. The Guide Information, Designs and/or Listings (files) must be presented in their entirety and in a non-misleading manner, without any manipulation of the data (or drawings). 2. The statement "Reprinted from the Online Certifications Directory with permission from Underwriters Laboratories Inc." must appear adjacent to the extracted material. In addition, the reprinted material must include a copyright notice in the following format: "Copyright © 2005 Underwriters Laboratories Inc.®"

KNLZ.GuideInfo

Commercial, with Integral Systems for Limiting the Emission of Grease-laden Air

[View Listings](#)[Page Bottom](#)[Print-friendly version](#)[Questions?](#)[Previous Page](#)

[Heaters and Heating Equipment] (Heaters, Cooking Appliances)

Commercial, with Integral Systems for Limiting the Emission of Grease-laden Air

[See General Information for Heaters, Cooking Appliances](#)

This category covers cooking equipment intended for commercial use, such as pressurized deep fat fryers and other appliances for use in commercial kitchens, restaurants or other business establishments where food is prepared. Each appliance covered in this category is manufactured with an integral system feature to limit the emission of grease-laden air from the cooking process to the room ambient.

These appliances have been evaluated for the limit of 5 mg/m³ for the emission of grease-laden air to the room ambient in accordance with the recommendations of the National Fire Protection Association Standard for Ventilation Control and Fire Protection of Commercial Cooking Operations, NFPA 96, using the EPA-202 test method prescribed for cooking appliances provided with integral recirculating air systems.

These products are not intended for connection to a ducted exhaust system.

Appliances in this category are not provided with an integral fire extinguishing system. Authorities having jurisdiction should be consulted as to the requirements for this equipment with respect to fire extinguishing systems, such as the need for field installed systems in accordance with NFPA 96.

For products with integral recirculating systems including fire extinguishing systems, refer to Commercial, with Integral Recirculating Systems ([KNKG](#)).

In cases where the nature or construction of equipment is such that special precautions beyond the requirements of the National Electrical Code must be observed in installations or use, suitable warning or special instructions are marked on the equipment.

Appliances Listed in this category are suitable for wiring with either copper or aluminum power supply conductors unless marked "Use Copper Wire Only For Power Supply Connections" .

Commercial cooking appliances of certain types are designed for permanent connections to water supply and sewer lines at the point of installation. Authorities having jurisdiction should be consulted as to the

requirements for this equipment with respect to sanitation and connection to water supply and waste disposal lines.

Neither the toxicity of coatings nor the physiological effects on persons consuming food products prepared by use of these appliances has been investigated.

The basic standard used to investigate products in this category is [ANSI/UL 197](#), "Commercial Electric Cooking Appliances".

Appliances Listed in this category with an integral cooking oil filter have been additionally investigated to the requirements in the standard "Commercial Filters for Cooking Oil", [ANSI/UL 1889](#). For cooking oil filters that are not an integral part of another appliance, see Commercial Filters for Cooking Oil ([KNRF](#)) in this directory.

The Listing Mark of Underwriters Laboratories Inc. on the product is the only method provided by UL to identify products manufactured under its Listing and Follow-Up Service. The Listing Mark for these products includes the name and/or symbol of Underwriters Laboratories Inc. (as illustrated in the Introduction of this Directory) together with the word "LISTED," a control number and one of the following product names as appropriate: "Commercial Cooking Appliance," "Cooking Appliance," or other appropriate product identity specified in the individual Listing, along with the words "with integral system for limiting the emission of grease-laden air. "

[Last Updated](#) on 1999-02-19

[Page Top](#)

[Notice of Disclaimer](#)

[Questions?](#)

[Previous Page](#)

[UL Listed and Classified Products](#)

[UL Recognized Components](#)

[Products Certified for Canada](#)

This page and all contents are Copyright © 2005 by Underwriters Laboratories Inc.®

The appearance of a company's name or product in this database does not in itself assure that products so identified have been manufactured under UL's Follow-Up Service. Only those products bearing the UL Mark should be considered to be Listed and covered under UL's Follow-Up Service. Always look for the Mark on the product.

UL permits the reproduction of the material contained in the Online Certification Directory subject to the following conditions: 1. The Guide Information, Designs and/or Listings (files) must be presented in their entirety and in a non-misleading manner, without any manipulation of the data (or drawings). 2. The statement "Reprinted from the Online Certifications Directory with permission from Underwriters Laboratories Inc." must appear adjacent to the extracted material. In addition, the reprinted material must include a copyright notice in the following format: "Copyright © 2005 Underwriters Laboratories Inc.®"

**BOARD OF
BUILDING AND SAFETY
COMMISSIONERS**

MARSHA L. BROWN
PRESIDENT

VAN AMBATELOS
VICE-PRESIDENT

VICTOR H. CUEVAS

HELENA JUBANY

ELENORE A. WILLIAMS

CITY OF LOS ANGELES

CALIFORNIA

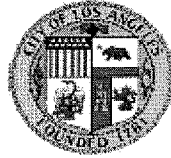

ANTONIO R. VILLARAIGOSA
MAYOR

**DEPARTMENT OF
BUILDING AND SAFETY**
201 NORTH FIGUEROA STREET
LOS ANGELES, CA 90012

ROBERT R. "BUD" OVRUM
GENERAL MANAGER

RAYMOND S. CHAN, C.E., S.E.
EXECUTIVE OFFICER

James K Pool
TurboChef Technologies
4240 International Parkway
Carrollton, TX 75007
Telephone: 214-908-8726

Models:

File Number: M-100012
Effective Date: 07/06/2011
Expiration Date: 04/01/2012
Manufacturer: SAME
Item: WARMING OVEN

HHB2*, NGC, NGO (*new model added).

PLEASE REFER TO THE APPLICATION NUMBER ON ALL CORRESPONDENCE, PHONE CALLS & SAMPLES

The item processed under the above file number has been tested, examined and found to comply with applicable Los Angeles Plumbing Code (LAPC) and/or Los Angeles Mechanical Code (LAMC) and is hereby approved unless revoked for cause.

This letter or the letterhead copy may not be reproduced for use in labeling or advertising, but copies of this letter may be used within your organization and shown as evidence of approval.

CONDITIONS OF APPROVAL:

- 1. This product shall be used to warm pre-cooked hot food items only. Any other type of cooking shall not be allowed.**
- 2. Installation of this product is not required to have an exhaust system per Sections 95.507.1.1 and 95.507.1.2 of LAMC, 2011 Edition.**
- 3. This product shall be installed, operated, and maintained in accordance with printed instructions from the manufacturer and LAMC, 2011 Edition.**

Each item shall have the name or trademark of manufacturer and model number where it will be visible for inspection.

In order to renew this approval, an application and reexamination fee must be submitted on or before the expiration date shown above. Arrangement shall be made to remove any test samples remaining in the Laboratory. Samples remaining after 21 days from the date of this notice will be shipped collect by the most convenient carrier or disposed of in accordance with applicable regulation.

Jason T Tran
Mechanical Testing Laboratory, Test Engineer

Plumbing / Mechanical Inspection
Inspection Bureau

Corporate Office 1930 S. Forest Hill Place, Danville, California 94526 p: 925.838.7561 f: 925.743.1568 www.fishnick.com
Mailing Address P.O. Box 1247, San Ramon, California 94583



April 22, 2005

TurboChef Technologies, Inc.
10500 Metric Drive, Suite 128
Dallas, Texas 75243

Dear Mr. Pool:

The eight-hour cooking emissions test on the High h Batch electric oven was completed as scheduled on April 13, 2005. The test samples have been analyzed and the total particulate matter (PM) concentration (mg/m^3) has been determined to be $1.088 \text{ mg}/\text{m}^3$ at an applied ventilation rate of 200 cfm.

The result of this test definitively supports the use of the High h Batch oven without the benefit of a Type I dedicated exhaust hood. Set against the pass/fail criteria of UL 197, the total PM concentration produced by the oven falls well below the standard's limit of $5.0 \text{ mg}/\text{m}^3$ for allowable grease emissions. Further, the measured total PM concentration of $1.088 \text{ mg}/\text{m}^3$ is below the $1.5 \text{ mg}/\text{m}^3$ limit adopted by some regulatory agencies.

The attached table summarizes the food product specifications, cooking parameters, constant test conditions and test results of the eight-hour cooking emissions test.

Also enclosed is the letter sent to the UL representative who was present during the test, Margaret Kiefer. Attached to the letter are the test measurements and official emissions test results as determined by PG&E's Technological and Ecological Services (TES) engineer, Clem DeSilva. Also, included are the calibration certificates for the air velocity meter used by Fisher Nickel Inc. technicians to determine the sampling exhaust duct's air velocity (ft/min) and the wet gas meter used by PG&E's TES personnel during the course of the test.

Please feel free to contact me should you have any questions or would like to further discuss the results of this test.

Sincerely,

Todd Bell
Emissions Researcher
Food Service Technology Center

Enclosures: 6

Emissions Testing Summary

Food Product Specification

Test Food Product.....	Pepperoni Pizza
Average Total Weight of each Pizza (lb).....	1.61

Cooking Parameters

Cook Time (minutes).....	1.83
Loading Time (seconds).....	.20
Removal Time (seconds).....	.20
Total Cooking Cycle (minutes).....	2.50
Pre-Cooking State (°F).....	38 ± 2.0
Number of Pizzas Cooked.....	192
Number of Pizzas per Load.....	1

Test Conditions

Sampling Time (hours).....	8
Exhaust Ventilation Rate (cfm).....	200
Number of Probe Sampling Points.....	3
Time Interval at each Sampling Point (minutes).....	30

Test Results

Total PM Concentration (mg/m ³).....	1.088
--	-------



2012-02-21

Mr. David Castillo
Turbochef Technologies Inc.
4240 International Pky
Carrollton, TX, 75007
United States

E-mail: David.Castillo@turbochef.com

Reference: File: TC8762 Project : 12CA05111 P.O. Number : N/A

Product: EPA 202 TEST METHOD: USING TURBOCHEF TECHNOLOGIES MODEL HHB2
CONVECTION OVEN WITH ORE-IDA FRIES, CHICKEN BREASTS, TYSON WINGS
AND GROUND BEEF PATTIES AS TEST MEDIA.

Dear Mr. Castillo,

Per your request, project 12CA05111 was opened for the evaluation of grease-laden vapors produced from cooking Ore-Ida Fries, Chicken Breasts, Tyson Wings, and Ground Beef Patties in a Turbochef Technologies Model HHB2 Convection Oven in accordance with your requested food load and test protocol.

The scope of this project was to determine the grease emissions from the Turbochef Technologies convection oven in accordance with EPA Method 202 test guidelines to demonstrate ultimate results to your specified food load and test protocol, which included UL710B, the Standard for Recirculating Systems, Sec. 17 and NFPA96, the Standard for Ventilation Control and Fire Protection of Commercial Cooking Operations, paragraph 4.1.1.2. The test was conducted at our facility in Northbrook, IL on February 9th, 2012. This letter will report the results of the EPA202 test.

For the record, the test was conducted using a UL Listed Turbochef Technologies Model HHB2 Convection oven found in E151487, Volume 1, Section 7, cooking Ore-Ida Fries, Chicken Breasts, Tyson Wings, and Ground Beef Patties as specified by Turbochef Technologies. Please see the attached page (Appendix A) for the test method and results of the test for Model HHB2. The results are considered to comply when tested with your specified food load and requested cook times since the total amount of grease-laden effluents collected was 0.10 mg/m³, which is less than 5 mg/m³ limit. No evaluation was conducted in regards to fire protection.

The issuance of this report in no way implies Listing, Classification, or Recognition by UL and does not authorize the use of UL Listing, Classification, or Recognition Marks or any other reference to UL on or in connection with the product or system.

You cannot use UL's name or marks in connection with any product, packaging, advertising, promotion, or marketing without UL's prior written permission.

In no event shall UL be responsible to anyone for whatever use or nonuse that is made of the information contained in this Report and in no event shall UL, its employees or its agents, incur any obligation or liability for damages, including, but not limited to, consequential damages arising out of or in connection with the use, or inability to use, of the information contained in this Report.

This letter will serve to report that all tests on the subject product have been completed. All information generated will be retained for future use. This concludes all work associated with Project 12CA05111 and we are therefore closing this project. Our Accounting Department has been instructed to bill you for all charges incurred.

Thank you for the opportunity to provide your company with these services. Please do not hesitate to contact us if you should have any questions or comments.

Very truly yours,

Reviewed by:



Bill Morler
Project Engineer
Department: 3015GNBK
Tel: 847-664-1852
Fax: 847-407-1852
E-mail: William.Morler@ul.com

Fred Zaplatosch
Staff Engineer
Department: 3015GNBK
E-mail: fred.zaplatosch@ul.com

APPENDIX: A

TEST FOR EVOLUTION OF SMOKE OR GREASE-LADEN AIR:

The Model HHB2 was tested using a method derived from EPA Method 202. The manufacturer also provided Ore-Ida Fries, Chicken Breasts, Tyson Wings, and Ground Beef Patties for the test.

A 12 in. by 6 in. rectangular, 108 in. tall sheet metal stack was constructed on top of a sheet metal hood and mounted above the exhaust vent of the convection oven. A sampling port was located approximately 80 in. downstream from the hood exhaust, at which point it was determined there was laminar flow. The sampler was assembled and an out of stack filter was used. A pre-leak check was conducted and determined to be > 0.02 ft/min. Sampling was determined to be done at 8 traverse points. A variable speed exhaust motor was used to maintain 500 CFM airflow through the exhaust stack.

The convection oven was operated normally by cooking the following foods:

One Complete Cooking Cycle

FOOD	# of Individual Cycles	Cook Time (min)	Weight of Product (oz.)	# of pieces per cycle	Product Temp before cooking
Ore Ida Thick Cut Fries	2	6:45	24	24 oz. Batch	Frozen
Chicken Breasts	2	6:50	5-6	4	36°F
Tyson Fire Wings	2	11:00	12	6	Frozen
Ground Beef Patties	2	6:00	6	6	37°F

The product consisted Ore-Ida Fries, Chicken Breasts, Tyson Wings, and Ground Beef Patties which was cooked at the specified amount of time as indicated above. The total oz. of product per cycle was distributed evenly throughout the pan. The cooking cycle was repeated for 8 hours of continuous cooking.

During the cooking operation, it was noted whether or not visible effluents evolved from the air exhaust of the hood. Gauge, meter and temperature readings were taken and recorded every 10 min.

After cooking, the condition of the duct was noted and a post-leak check was conducted and determined to be $< 0.02 \text{ ft}^3/\text{min}$.

After being allowed to cool, the sampling equipment was disassembled; the filter was removed, and placed into a sample container labeled No. 1. The liquid in impingers Nos. 1, 2, and 3 were volumetrically measured and transferred to sample container No. 3. The silica gel and impinger No. 4 was transferred to sample container No. 5. The nozzle, probe and impingers were rinsed three times with water and the rinse was added to container No. 3. These parts were also rinsed three times with acetone and transferred to container No. 4. All additional inter surfaces of the sampling terrain glassware were rinsed with methylene chloride three times; the rinse was transferred to container No. 6. A blank of acetone approximately equivalent to the amount used for rinses was aliquoted into container No. 2, the same was done for the distilled de-ionized water and methylene chloride except that these were aliquoted into their own individual containers labeled No. 7 and 8 respectively. All containers were properly labeled and sealed, then the liquid levels in all the containers were marked.

The analysis phase was done in accordance with EPA Method 202, using the out of stack filter.

RESULTS:

There was no visible smoke emitted from the exhaust of the hood during the normal cooking operation of the Model HHB2. There was no noticeable amount of smoke accumulated in the test room after 8 hours of continuous cooking.

There was no visible smoke was emitted from the exhaust of the hood during the normal cooking operation. There was no noticeable amount of smoke accumulated in the test room after 8 hours of continuous cooking.

The total amount of grease-laden effluents collected by the sampling equipment was found to be $0.10 \text{ mg}/\text{m}^3$, which is less than $5 \text{ mg}/\text{m}^3$.

TEST LOCATION:					
<input checked="" type="checkbox"/> UL or Affiliate	<input type="checkbox"/> WTDP	<input type="checkbox"/> CTDP	<input type="checkbox"/> TPTDP	<input type="checkbox"/> TCP	<input type="checkbox"/> PPP
	<input type="checkbox"/> WMT	<input type="checkbox"/> TMP	<input type="checkbox"/> SMT		
Company Name Underwriters Laboratories					
Address 333 Pfingsten Rd, Northbrook IL, 60069					

CLIENT INFORMATION	
Company Name	TurboChef Technologies Inc.
Address	4240 International Pky Carrollton TX, 75007

AUDIT INFORMATION:				
Description of Tests	Per Standard No.	UL-710B CSA 22.2 109-M1981	Edition/ Revision Dates	2 nd / September 2 nd 2011 1 st / April-1989 (r2004)
Tests Conducted by +			Ken Kingsbury/Mike Chieffo	
		Printed Name		Signature
Reviewed and accepted by qualified Project Handler	William G. Morler		<i>William G. Morler</i>	
		Printed Name		Signature

TESTS TO BE CONDUCTED:				
Test No.	Start	Done+++	Test Name	Comments/Parameters [x]Tests Conducted by ++
1	2012-2-6	2012-2-17	POWER INPUT TEST	
2	2012-2-9	2012-2-9	DIELECTRIC VOLTAGE-WITHSTAND	
3	2012-2-9	2012-2-9	CAPTURE TEST	
4	2012-2-9	2012-02-14	EPA 202 TEST	++Shane M. Keller / Joe Garrett

Description of Tests	Per Standard No.	UL-197 CSA 22.2 109-M1981	Edition/ Revision Date	10 TH 2004
Description of Tests	Per Standard No.	UL-710B	Edition/ Date	2 nd 2004

GENERAL TEST CONSIDERATIONS - ALL TESTS:

Power Supply Connections

Unless otherwise specified in the individual test methods, the appliance was connected to a 240 volt source of supply at 60 Hz.

This supply connection was based on

- The marked voltage rating
 The highest voltage of the applicable range of voltages

RISK ANALYSIS RELATED TO TESTING PERFORMANCE:

The following types of risks have been identified. Take necessary precautions. This list is not all inclusive.

<input checked="" type="checkbox"/> Electric shock	<input type="checkbox"/> Radiation
<input checked="" type="checkbox"/> Energy related hazards	<input type="checkbox"/> Chemical hazards
<input type="checkbox"/> Fire	<input type="checkbox"/> Noise
<input checked="" type="checkbox"/> Heat related hazards	<input type="checkbox"/> Vibration
<input type="checkbox"/> Mechanical	<input type="checkbox"/> Other (Specify)___

TEST EQUIPMENT INFORMATION

Inst. ID No.	Instrument Type	Test Number +, Test Title or Conditioning	Function /Range	Last Cal. Date	Next Cal. Date

+ - If Test Number is used, the Test Number must be identified on the data sheet pages or on the Data Sheet Package cover page.

The following additional information is required when using client's or rented equipment, or when a UL ID Number for an instrument number is not used. The Inst. ID No. below corresponds to the Inst. ID No. above.

Inst. ID No.	Make/Model/Serial Number/Asset No.

UL test equipment information is recorded on Meter Use in UL's Laboratory Project Management (LPM) database.

TEST SAMPLE IDENTIFICATION:

The table below is provided to provide correlation of sample numbers to specific product related information. Refer to this table when a test identifies a test sample by "Sample No." only.

Sample Card No.	Date Received	Test No.+	Sample No.	Manufacturer, Product Identification and Ratings
1284753	2012-01-13	ALL	1	Turbochef Technologies Inc., Model HHB2, rated 240 V, 6900 W.

POWER INPUT TEST (110-120V):
RATING (CSA 22.2 109-M1981):

UL 710B Sec. 44
(6.2)

METHOD

The supply voltage was adjusted to voltage and frequency as noted in "General Test Considerations", [240 V], [60 Hz].

The supply voltage was voltage adjusted to the mean of the rated voltage range at rated frequency, [___ V], [___ Hz].

The power input was measured with the appliance at the intended operating temperature under full-load conditions.

[For appliances incorporating a general-use receptacle connected to the same electrical source supplying the appliance]

The added load placed on the receptacle was 80 percent of the current rating of the receptacle.

The added load placed on the duplex receptacle was 100 percent of the current rating of the receptacle.

The added load placed on the receptacle was the specific marked load intended to be used during operation.

To determine the proper test voltage for the Normal Temperature and Abnormal Heating Tests, the voltage was then adjusted to the value necessary to cause the appliance to draw its rated [current] [and] [power].

[Test to determine proper test voltage for c-UL testing]

The supply voltage was adjusted to the increased test voltage as noted below. Following the test at increased test voltage, the supply voltage was adjusted to the value necessary to cause the appliance to draw the increased test [current] [and] [power], calculated as specified below.

Increased Test Voltage (V_t): 125V for appliances rated between 110V-125V.

Increased Test Current (I_t): $I_r(V_t/V_r) = \text{_____ A}$

Increased Test Power (W_t): $W_r(V_t/V_r)^2 = \text{_____ (W)(kW)}$

Where V_r , I_r , and W_r , are the rated voltage, current, and power of the appliance, respectively. Note: when the appliance is rated for a range of voltages, the mean of the range is to be used as V_r .

PARAMETERS

Appliance Ratings:

Volts: 208/240; Current: 28.8 A; Power: 6900 W

POWER INPUT TEST (110-120V): (CONT'D)
 RATING (CSA 22.2 109-M1981):

UL 710B Sec. 44
 (6.2)

RESULTS

Operating Conditions	Rated			Measured		
	Volts	Amps	Power, (W)	Volts	Amps	Power, (W)
Full power operation, rated voltage	240	---	---	240	27.4	6576
<input type="checkbox"/> Full power operation, rated current	---		---			
<input checked="" type="checkbox"/> Full power operation, rated power	---	---	6900	256.5	28.9	6909

The input current [was] [was not] between 90% and 105% of the rated input current when the appliance was energized at rated voltage.

The input power ~~[was]~~ [was not] between 90% and 105% of the rated input power when the appliance was energized at rated voltage.

DIELECTRIC VOLTAGE-WITHSTAND TEST:
DIELECTRIC STRENGTH (CSA 22.2 109-M1981):

UL 710B Sec. 46
(6.7)

METHOD

The test was conducted with equipment employing a 500 volt-ampere or larger capacity transformer capable of manual or automatic regulation of the output voltage. The equipment used was an [Associated Research Model 3665.

The applied potential was increased from zero to the required value in a uniform rate. This potential was held at that value for 1 minute.

During the test, all contacts energizing current-carrying parts (such as conductors, relays, and thermostats) were in the closed position.

PRIMARY CIRCUITS

The appliance was operated for 8 hours, sufficient to allow it to attain maximum operating temperature under conditions of intended use.

The appliance was subjected to the application of a 40 - 70 hertz essentially sinusoidal potential for 1 minute without electrical breakdown:

- Between live parts of primary circuits and dead metal parts;
- Between live parts of different primary circuits;
- Between terminals of a capacitor used across-the-line
- Between terminals of a capacitor connected between the line and the enclosure.

The test potential was 1000 volts.

RESULTS

In each case there [~~was~~] [was no] dielectric breakdown.

Operation of the test equipment was checked before and after the test by observing breaker operation with:

- leads connected together
- a checking resistor

CAPTURE TEST:

UL 710B Sec. 58

UL 710 Sec. 31

METHOD

The model HHB2 cooking appliance was placed under a hood, located in a draft free room and is operated at the lower air flow limit (500 CFM). Food product as specified below was then used for testing, see Emission Testing for specific details. The cooking area is to be observed for the presence of visible smoke and grease-laden air, and the hood assembly shall completely capture all of the emission as determined by observation.

COOKING PRODUCT

One Complete Cycle

FOOD	# of Individual Cycles	Cook Time (min)	Weight of Product (oz.)	# of pieces per cycle	Product Temp before cooking
Ore Ida Thick Cut Fries	2	6:45	24	24 oz. Batch	Frozen
Chicken Breasts	2	6:50	5-6	4	36°F
Tyson Fire Wings	2	11:00	12	6	Frozen
Ground Beef Patties	2	*6:00	6	6	37°F

COOKING METHOD

The product was cooked per the manufactures recommendations, as specified above.

RESULTS

Their [~~was~~] [was not] the presence of visible smoke and grease-laden air from the appliance during testing.

The sample [did] [~~did not~~] capture all of the emissions from the cooking appliance.

(*) Note: The cook time for the ground beef patties was changed from 5 minutes to 6 minutes due to the burgers not being cooked all the way through.
mac 2012-2-17

EMISSION TEST:

UL 710B Sec. 59

METHOD

TEST FOR EVOLUTION OF SMOKE OR GREASE-LADEN AIR

The model HHB2 cooking appliance was placed under a hood overall 48 by 41 by 96 in. with the hood airflow at 500 CFM, and is tested using a method derived from EPA Method 202. Underwriters Laboratories also provided the following products for the test, Ore Ida Thick Cut Fries, Chicken Breasts, Tyson Fire Wings and Ground Beef Patties.

A 12 in. by 6 in. rectangular, 108 in. tall sheet metal stack was constructed on top of the sheet metal hood and mounted above the exhaust vent of the hood. A sampling port was located approximately 80 in. downstream from the hood exhaust, at which point it was determined there was laminar flow. The sampler was assembled and an out of stack filter was used. A pre-leak check was conducted and determined to be < 0.02 ft/min. Sampling was determined to be done at 8 traverse points.

The oven was operated normally by cooking the following foods:

One Complete Cycle

FOOD	# of Individual Cycles	Cook Time (min)	Weight of Product (oz.)	# of pieces per cycle	Product Temp before cooking
Ore Ida Thick Cut Fries	2	6:45	24	24 oz. Batch	Frozen
Chicken Breasts	2	6:50	5-6	4	36°F
Tyson Fire Wings	2	11:00	12	6	Frozen
Ground Beef Patties	2	*6:00	6	6	37°F

The cooking cycle was repeated for 8 hours of continuous cooking. This resulted in 8 complete cycles.

During the cooking operation, it was noted whether or not visible effluents evolved from the air exhaust of the hood. Gauge, meter and temperature readings were taken and recorded every 10 min. After cooking, the condition of the duct was noted and a post-leak check was conducted and determined to be < 0.02 ft³/min.

(*) Note: The cook time for the ground beef patties was changed from 5 minutes to 6 minutes due to the burgers not being cooked all the way through. mac 2012-2-17.

EMISSION TEST:

UL 710B Sec. 59

After being allowed to cool, the sampling equipment was disassembled. The glass-filter is to be removed using a pair of forceps and placed in a clean petri dish. The dish is to be sealed and labeled "sample 1".

A sample of the acetone of the same volume that will be used to rinse-out the nozzle and probe is to be placed into a clean sample bottle, sealed, and labeled "sample 2". The level of the liquid in the sample bottle is to be recorded.

The inside of the nozzle and probe is to be rinsed with acetone taking care to collect all the rinse material in a clean sample bottle. The sample bottle is to be sealed, labeled "sample 3", and the level of the liquid in the bottle is to be recorded.

The liquid in the first three impingers is to be measured and the total volume is to be recorded which will be compared to the original volume. The liquid is to be quantitatively transferred to a clean sample bottle. Each impinger and the connecting glassware including the probe extension are to be rinsed twice with water. The rinse water is to be collected and added to the same sample bottle. The sample bottle is to be sealed, labeled "sample 4" and the level of the liquid in the bottle is to be recorded.

This rinse process is to be repeated with two rinses of methylene chloride (MeCl_2). The rinses are to be recovered in a clean sample bottle. The sample bottle is to be sealed, labeled "sample 5" and the level of the liquid in the bottle is to be recorded.

A volume of water approximately equivalent to the volume of water used to rinse and a volume of MeCl_2 approximately equivalent to the volume of MeCl_2 used to rinse is to be placed in two clean sample bottles. The sample bottles are to be sealed, labeled "sample 6" and "sample 7" respectively, and the level of the liquid in the bottles is to be recorded.

The weight of the fourth impinger containing the silica gel is to be recorded and then the silica gel can be discarded.

The analysis phase was done in accordance with EPA Method 202, using the out of stack filter.

RESULTS

The results [are] [~~are not~~] considered acceptable because there [was] [was no] visible smoke emitted from the exhaust of the hood during the normal cooking operation. There [was] [was no] noticeable amounts of smoke accumulated in the test room after 8 hours of continuous cooking.

The total amount of grease-laden effluents collected by the sampling equipment was found to be 0.10 mg/m³, which is [less] [~~more~~] than 5 mg/m³.

Note: Additional spreadsheet is to be used when conducting the Emission Test. This spreadsheet (EPA 202) can be found in the Lab Equipment Management System (LEM) under global ID 58255.

EMISSION TEST:

UL 710B Sec. 59

CONDENSIBLE MATTER
(Lab Analysis)

Sample Bottle No.	Description	Volume, ml	Final Wt, mg
1	Filter Paper	-	651.9
2	Acetone (Blank)	19	0.2
3	Acetone (Wash)	15	0.3
4&5	Solvent Phase(Wash)	90	0.7
4&5	Water Phase (Wash)	365	1.9
6&7	Solvent Phase (Blank)	120	0.8
6&7	Water Phase (Blank)	375	1.2

Filter paper weight before test- 652.3 mg

EMISSION TEST:

UL 710B Sec. 59

Analysis

1. The liquid level of all the sample bottles is to be measured.
2. The filter from sample one is to be removed and dried to constant weight by means of a desiccator or an oven. The weight of the filter is to be recorded.
3. The volume of sample two is to be determined. The liquid is then to be transferred to a beaker and evaporated to dryness. The volume of the liquid and the final weight of the condensable matter are to be recorded.
4. The volume of sample three is to be determined. The liquid is then to be transferred to a beaker and evaporated to dryness. The volume of the liquid and the final weight of the condensable matter are to be recorded.
5. The volumes of sample four and five are to be measured.
6. Samples four and five are to be combined. The solvent phase is to be mixed, separated, and then repeated with two MeCl₂ washes.
7. The solvent extracts obtained from the procedure in 6 are to be placed in a beaker and evaporated to a constant weight. The final weight is to be recorded.
8. The water phase is to be placed in a beaker and evaporated to dryness. The final weight is to be recorded.
9. The volumes of samples six and seven are to be determined. Sample bottles six and seven are to be analyzed according to procedures 8 and 7 respectively.

END OF DATASHEET PACKAGE. THIS PAGE INTENTIONALLY LEFT BLANK

File: TC8762

Project: 12CA05111

Date: 2/9/2012

Client:

Turbochef Technologies

Model:

HHB2

Product Tested

Hamburger, Chicken, Wings, Fries

Turbochef Technologies

Model: **HHB2**

Calculations needed for Nozzle Size

$\Delta H@$ = 40.124 This number is calculated when device is calibrated

% Oxygen = 21.14 %O₂ Oxygen inside stack during operation

% Carbon = 0.01 %CO₂ Carbon Dioxide inside stack during operation

Stack Temperature = 25.81 °C Temperature inside stack during operation

Barametric Pressure = 749.3 mmHg Barametric pressure at location of meter

Stack Static Pressure = -1.016 mm H₂O Static Pressure inside of duct

Average Square root ΔP = 1.667 ΔP mm H₂O Enter pressure differential at each traverse point in mm H₂O, the take square root of ΔP .

	Pressure	CFM		Pressure
1	2.032	505	5	3.048
2	2.54	505	6	3.048
3	2.54	489	7	3.048
4	2.794	510	8	3.302

Average

Traverse Points = 8

Meter Temperature = 25 °C

Pitot Tube Coefficient = 0.84

% Moisture = 21.58

Sample Rate = 21.24 Lpm

Ideal Nozzle Size = 9.817 mm When numbers are entered into calculator, ideal nozzle size will be displayed. Enter number here
3/8 in

Actual Nozzle Size Used = in If ideal nozzle size is not available, locate nearest number. Enter what nozzle size was used for testing

Turbochef Technologies

Model: **HHB2**

Start Time: **7:30**

Product Tested: **Hamburger, Chicken, Wings, Fri**

Cook Time: **cycle**

End Time: **16:00**

Barometric Pressure: 749.3 mmHg

Recovery Time: **n/a**

Test Date: 2012/02/09

Room Ambient: **25**

IMPINGER WEIGHT

Impinger	Start Volume/Weight	Empty Weight (lbs)	With Content (lbs)	End of Test (lbs)
1	100mL	1.316	1.538	1.330
2	100mL	1.302	1.520	1.592
3	0	1.334	1.334	1.398
4	200g	1.296	1.738	1.882

FILTER WEIGHT

	1	2	3	4	5	6	7	End Weight
#1- Beginning	0.6418	0.6404	0.6414	0.6426	0.642			
#1- End								
#2- Beginning	0.6529	0.6541	0.6533	0.6525	0.6523			0.6523
#2- End	0.659	0.6573	0.6563	0.6534	0.6528	0.652	0.6519	0.6519

Timed Meter Readings

Traverse Point Number	Sampling Time Hr/Sec	Gas Meter Reading (m ³)	Orifice Pressure Differential ΔH	Velocity Head ΔP	Pump Vaccum In.hg	Stack Temp °C	Probe Temp °C	Filter Temp °C	Exit Temp °C	Gas Meter Temp °C
Initial	-	339.883	40	1.6	0.0	26	121	121	10	22
1	10	340.088	41	1.6	0.0	26	121	121	12	23
1	20	340.295	42	1.6	1.0	26	121	121	14	24
1	30	340.503	42	1.6	1.0	26	121	121	16	25
1	40	340.712	42	1.6	1.0	26	121	121	12	26
1	50	340.922	42	1.6	1.0	25	121	121	12	27
1	60	341.131	42	1.6	1.0	25	121	121	14	27
2	10	341.341	42	2.0	1.0	26	121	121	14	28
2	20	341.551	42	2.0	1.0	26	121	121	15	28
2	30	341.761	42	2.0	1.0	27	121	121	13	28

2	40	341.971	42	1.8	1.0	26	121	121	13	28
2	50	342.181	42	2.0	1.0	26	121	121	15	29
2	60	342.392	43	1.8	1.0	27	121	121	12	29

Traverse Point Number	Sampling Time Hr/Sec	Gas Meter Reading (m ³)	Orifice Pressure Differential ΔH	Velocity Head ΔP	Pump Vacuum In.hg	Stack Temp °C	Probe Temp °C	Box Temp °C	Impinger Temp °C	Gas Meter Outlet °C
3	10	342.600	41	2.0	1.0	26	121	121	13	29
3	20	342.807	42	2.0	1.0	27	121	121	14	29
3	30	343.015	41	2.0	1.0	28	121	121	15	29
3	40	343.223	42	2.0	1.0	26	121	121	13	29
3	50	343.437	41	2.0	1.1	26	121	121	13	29
3	60	343.642	41	2.0	1.1	26	121	121	14	29
4	10	343.847	42	1.6	1.1	26	121	121	15	29
4	20	344.056	42	1.6	1.1	27	121	121	13	29
4	30	344.264	42	1.8	1.1	27	121	121	13	29
4	40	344.472	42	1.8	1.1	27	121	121	14	29
4	50	344.680	42	1.8	1.1	26	121	121	15	29
4	60	344.889	42	1.8	1.1	26	121	121	11	29
5	10	345.098	42	1.8	1.1	27	121	121	12	29
5	20	345.306	42	1.8	1.1	26	121	121	13	29
5	30	345.514	41	1.8	1.1	26	121	121	14	29
5	40	345.723	42	1.8	1.1	26	121	121	12	29
5	50	345.930	41	1.8	1.1	26	121	121	12	29
5	60	346.138	42	1.8	1.1	25	121	121	13	29
6	10	346.345	41	2.1	1.1	26	121	121	14	29
6	20	346.553	41	2.0	1.1	27	121	121	15	29
6	30	346.760	42	2.0	1.1	27	121	121	11	29
6	40	346.968	42	2.0	1.1	27	121	121	11	29
6	50	347.176	42	2.0	1.1	26	121	121	12	29
6	60	347.383	41	2.0	1.1	26	121	121	13	29
7	10	347.590	42	2.0	1.1	26	121	121	14	29
7	20	347.798	42	2.2	1.1	26	121	121	11	29
7	30	348.005	41	2.2	1.1	26	121	121	11	29
7	40	348.212	41	2.2	1.1	26	121	121	12	29
7	50	384.422	41	2.2	1.1	27	121	121	13	29
7	60	348.626	41	2.2	1.1	26	121	121	13	29
8	10	348.834	42	2.0	1.5	26	121	121	14	29
8	20	349.042	42	2.0	1.5	26	121	121	14	29
8	30	349.251	42	2.0	1.5	26	121	121	14	29
8	40	349.460	42	2.0	1.5	26	121	121	15	29
8	50	349.668	42	2.0	1.5	27	121	121	15	29
8	60	349.877	42	2.0	1.5	26	121	122	12	29

8	70	350.086	42	2	1.5	26	121	121	11	29
8	80	350.295	42	2	1.5	25	121	121	12	29
8	90	350.503	42	2	1.5	26	121	121	12	29

Average Gas Meter Outlet Temperature: 28.32653 °C

Average Gas Meter Outlet Temperature: 82.98776 °F

$$\Delta H = \underline{41.7451} \text{ mm H}_2\text{O}$$

$$T_m = \underline{542.99} \text{ R}$$

$$\Delta H = \underline{1.643508} \text{ in H}_2\text{O}$$

Project No. 12CA05111

File: TC8762

Turbochef Technologies

Model: HHB2

Start Volume of Sample Bottles

Sample Bottle	Start Volume (ml)	Sample Bottle	Start Volume (ml)
2	19.0	5	90.0
3	15.0	6	375.0
4	365.0	7	120.0

Initial Weight of Dishes And Drying Process

	Initial Weight (g)	Drying Process (g)						Final Weight of Dish
		1	2	3	4	5	6	
Dish 1								
Dish 2	0.9801	0.9802	0.9802					0.9802
Dish 3	0.9806	0.9807	0.9807					0.9807
Dish 4	1.0026	1.0028	1.0027					1.0027
Dish 5	1.0018	1.0018	1.0016					1.0016
Dish 6	0.9797	0.9799	0.9799					0.9799
Dish 7	0.9942	0.9944	0.9944					0.9944
Dish 8								
Dish 9								
Dish 10								

Initial Weight of Bottle 2 And Drying Process

	Enter Dish #	Final Weight of Dish	Solid Phase Drying Process (g)					Final Weight After Drying
			1	2	3	4	5	
Dish	2	0.9802	0.9804	0.9804				0.9804
Dish								
Dish								

Final Weight of Bottle 2

Dish #	Final Weight of Dish (Pre-dry)	Final Weight of Dish (Post-dry)
Dish 2	0.9802	0.9804

Final Weight of Bottle 2 Solids

0.0002 grams

Dish	0	0.0000	0.0000
Dish	0	0.0000	0.0000

0.2	milligrams
-----	------------

Initial Weight of Bottle 3 And Drying Process

	Enter Dish #	Final Weight of Dish	Solid Phase Drying Process (g)					Final Weight After Drying
			1	2	3	4	5	
Dish	3	0.9807	0.9809	0.9810				0.981
Dish								
Dish								

Final Weight of Bottle 3

	Dish #	Final Weight of Dish (Pre-dry)	Final Weight of Dish (Post-dry)
Dish	3	0.9807	0.9810
Dish	0	0.0000	0.0000
Dish	0	0.0000	0.0000

Final Weight of Bottle 3 Solids	
0.0003	grams
0.3	milligrams

Initial Weight of Bottles 4 & 5 And Drying Process (Solvent Phase)

	Enter Dish #	Final Weight of Dish	Solid Phase Drying Process (g)					Final Weight After Drying
			1	2	3	4	5	
Dish	5	1.0016	1.0023	1.0023				1.0023
Dish								
Dish								

Final Weight of Bottles 4 & 5 (Solvent Phase)

	Dish #	Final Weight of Dish (Pre-dry)	Final Weight of Dish (Post-dry)
Dish	5	1.0016	1.0023
Dish	0	0.0000	0.0000
Dish	0	0.0000	0.0000

Final Weight of Bottles 4 & 5 Solids	
0.0007	grams
0.7	milligrams

Initial Weight of Bottles 4 & 5 And Drying Process (Water Phase)

	Enter Dish #	Final Weight of Dish	Solid Phase Drying Process (g)					Final Weight After Drying
			1	2	3	4	5	
Dish	4	1.0027	1.0044	1.0046				1.0046

Dish								
Dish								

Final Weight of Bottles 4 & 5 (Water Phase)

	Dish #	Final Weight of Dish (Pre-dry)	Final Weight of Dish (Post-dry)	Final Weight of Bottles 4 & 5 Solids	
Dish	4	1.0027	1.0046	0.0019	grams
Dish	0	0.0000	0.0000	1.9	milligrams
Dish	0	0.0000	0.0000		

Initial Weight of Bottles 6 & 7 And Drying Process (Solvent Phase)

	Enter Dish #	Final Weight of Dish	Solid Phase Drying Process (g)					Final Weight After Drying
			1	2	3	4	5	
Dish	7	0.9944	0.9953	0.9952				0.9952
Dish								
Dish								

Final Weight of Bottles 6 & 7 (Solvent Phase)

	Dish #	Final Weight of Dish (Pre-dry)	Final Weight of Dish (Post-dry)	Final Weight of Bottles 6 & 7 Solids	
Dish	7	0.9944	0.9952	0.0008	grams
Dish	0	0.0000	0.0000	0.8	milligrams
Dish	0	0.0000	0.0000		

Initial Weight of Bottles 6 & 7 And Drying Process (Water Phase)

	Enter Dish #	Final Weight of Dish	Solid Phase Drying Process (g)					Final Weight After Drying
			1	2	3	4	5	
Dish	6	0.9799	0.9811	0.9811				0.9811
Dish								
Dish								

Final Weight of Bottles 6 & 7 (Water Phase)

	Dish #	Final Weight of Dish (Pre-dry)	Final Weight of Dish (Post-dry)	Final Weight of Bottles 6 & 7 Solids	
Dish	6	0.9799	0.9811	0.0012	grams

Dish	0	0.0000	0.0000
Dish	0	0.0000	0.0000

1.2	milligrams
-----	------------

Final Weight of All Bottles

Sample Bottle	2
---------------	---

0.2	milligrams
-----	------------

Sample Bottle 4&5	Water Ph.
-------------------	-----------

1.9	milligrams
-----	------------

Sample Bottle	3
---------------	---

0.3	milligrams
-----	------------

Sample Bottle 6&7	Solvent Ph.
-------------------	-------------

0.8	milligrams
-----	------------

Sample Bottle 4&5	Solvent Ph.
-------------------	-------------

0.7	milligrams
-----	------------

Sample Bottle 6&7	Water Ph.
-------------------	-----------

1.2	milligrams
-----	------------

Project No. 12CA05111

File: TC8762

Turbochef Technologies

Model: HHB2

Start Time:	<u>7:30</u>	End Time:	<u>16:00</u>	Test Date:	<u>02/09/12</u>
Cook Time:	<u>cycle</u>	Product Tested:	Hamburger, Chicken, Wings, Fries		
Recovery Time:	<u>n/a</u>	Barometric Pressure:	<u>749.3</u>		

Post-Test Data

Gas Meter Reading initial	339.88 m ³	Gas Meter Reading End	349.88 m ³
Vm	9.99 m ³ 352.93 ft ³		
Y- Constant	<input type="text" value="0.934"/>	This data is obtained during device calibration. Verify number with most recent calibration certification on LEM	
Tstd constant	528.0 R		
Tm	543.0 R	Number obtained from Datasheet	
Barometric Pressure	749.3 mmHg 29.5 inHg	Barometric Pressure on day of Test	
Pstd	30.42 inHg		
Δ H	1.643508 in H ₂ O		
Vmstd	312.12 ft ³ 8.838292 m ³		

Post-Filter Data

Filter paper	651.9 mg	Weight at End of Test
Filter AR	652.3 mg	Weight at Beginning of Test
delta H	0.4 mg	Change of Weight at End of Test

Post-Acid Used

Acetone (Blank)	0.2 mg	Bottle 2	Mc	0.5 mg
Acetone (Wash)	0.3 mg	Bottle 3		
Solvent Phase (Wash)	0.7 mg	Bottles 4&5	Mn	0.9 mg
Water Phase (Wash)	1.9 mg	Bottles 4&5		
Solvent Phase (Blank)	0.8 mg	Bottles 6&7		
Water Phase (Blank)	1.2 mg	Bottles 6&7		

Total Grease EmissionsCs=Mn/Vmstd **0.10 mg/m³**

Ventless Operation

- Particulate Matter Emissions During 8 hr of Pizza Barreling. UL LIMIT 5.0mg/m³ @ 500 cfm

(source Food Service Technology Center/UL)

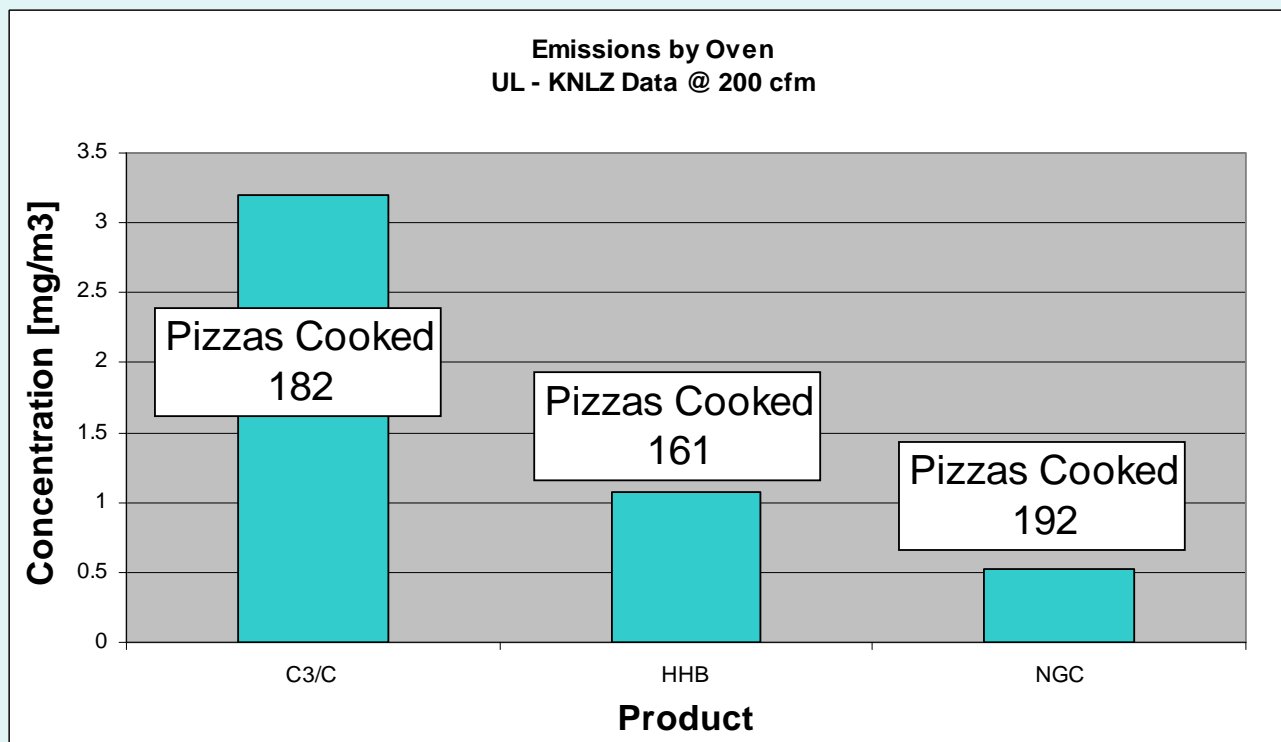

Appliance

Make:	TurboChef
Model:	High h Batch

Food Product: **Chicken Breasts**

Preheat and Idle data (475°F)

Preheat Time:	12.9	min
Preheat Energy:	1.1	kWh
Idle Energy Rate:	1.4	kW

Chicken Baking Performance

Bake Time:	8.5	min
Baking Energy Rate:	4.0	kW
Baking Energy Efficiency:	36.3	%
Production Capacity:	10.8	lb/h
Product Shrinkage	33.5	%

Food Product: **Cheese Pizza**

Preheat and Idle data (525°F)

Preheat Time:	14.8	min
Preheat Energy:	1.3	kWh
Idle Energy Rate:	1.5	kW

Pizza Baking Performance

Bake Time:	2.0	min
Baking Energy Rate:	5.3	kW
Baking Energy Efficiency:	37.2	%
Production Capacity:	42.3	lb/h

Pizza Barreling Performance

Baking Energy Rate:	Run#1	4.8	kW
	Run#2	5.0	kW
	Run#3	4.8	kW
	Run#4	4.4	kW
	Run#5	4.8	kW
	Run#6	4.8	kW
	Run#7	5.0	kW
	Run#8	5.0	kW

Average kW: **4.8** kW

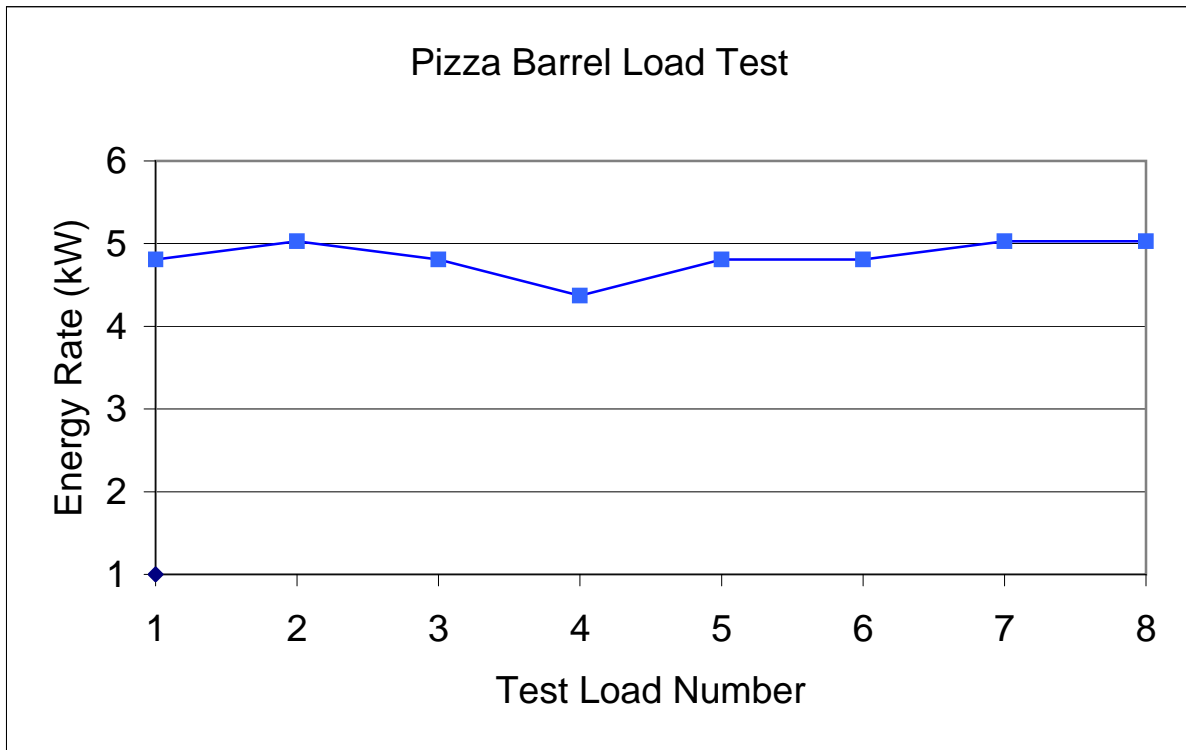

HHB (1 OR 3 PHASE)



Changeable Parameters		
Operating Time	8	Hours
Energy Costs	\$0.11	kWhr
Snooze Mode	0.00	Hours
Cook Cycles/Day	25	Cooks/Day
Typical Cook Time	180	Seconds

Do Not Change the following values

	Time (min)	Power (Watts)	Cost/Day	Balance of Time (hrs)
Warm up	15	5200	\$0.14	7.75
Cooking	75	4650	\$0.64	6.50
Snooze Idle	0	0	\$0.00	6.50
Idle	390	1450	\$1.04	0
Total/Day			\$1.82	Yearly
Total/Month			\$54.57	\$654.89

HVAC Requirements Per Operating Time -- Note: Approximations Only

Average Energy Cooking And Idle (J)	Warmup Energy (J)	Total Energy (J)	Total average Power (W)	Total Environmental Load kBtu/hr	Average Cooling Requirement (ton of AC)
54855000	4680000	59535000	2067	7	0.588

HhB 2 Oven Surface Temperatures

The illustrations in this document represent the surface testing data reported for the TurboChef oven model HhB 2 after four hours of idle, and then subsequently two hours of cooking.

After Four-Hour Idle (Fahrenheit)

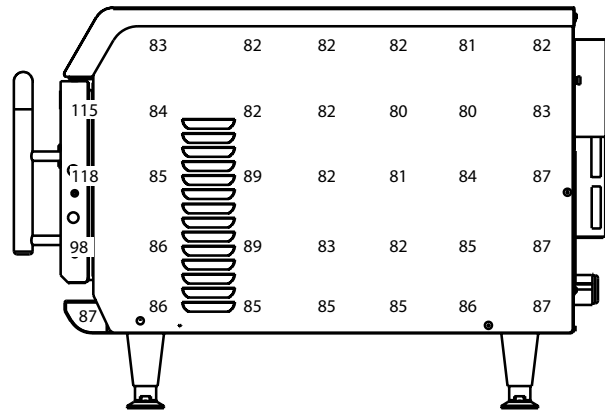
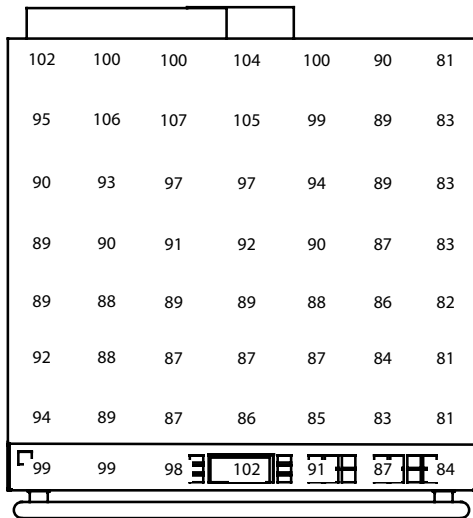
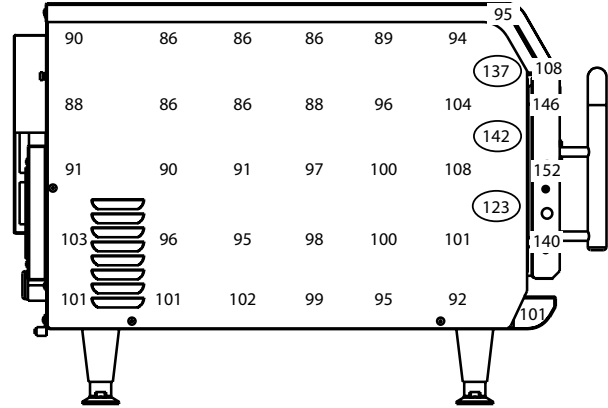
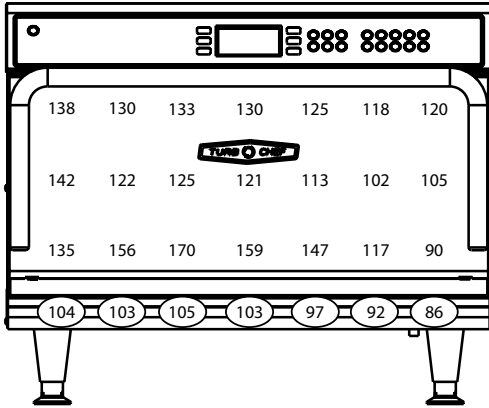

After Four-Hour Idle, Then Two Hours of Cooking (Fahrenheit)

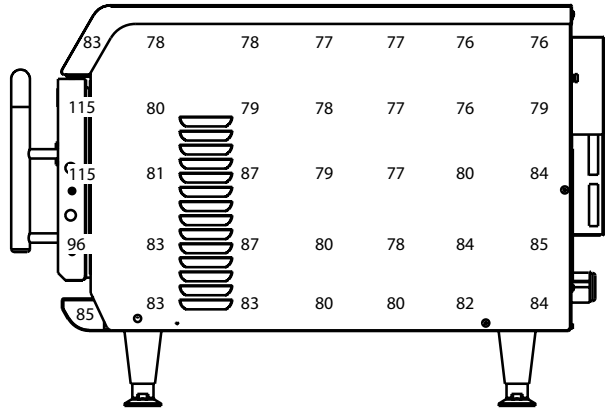
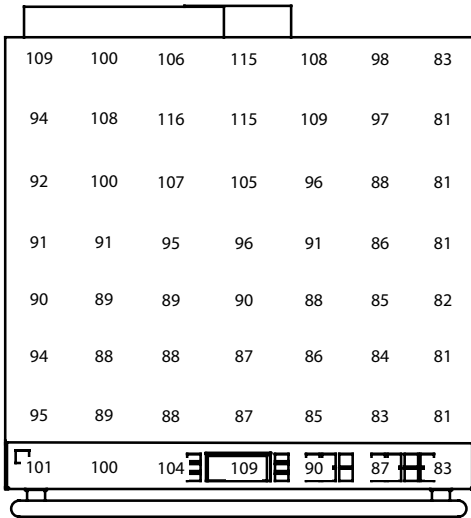
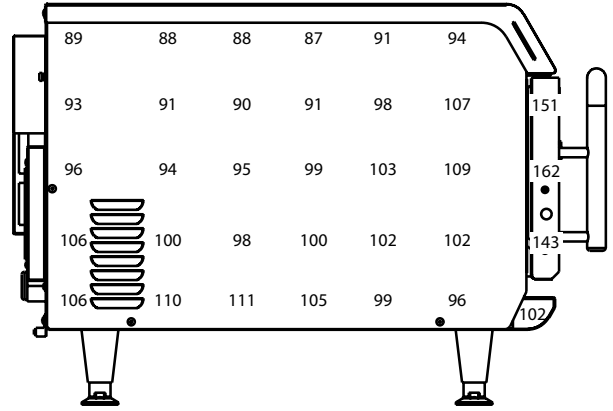
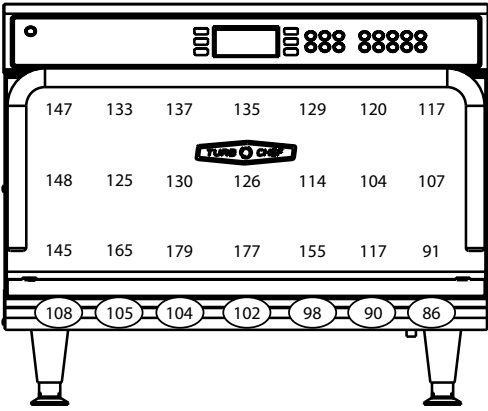

After Four-Hour Idle (Celsius)

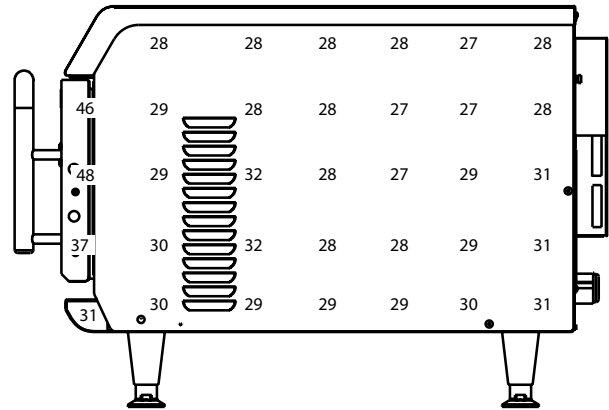
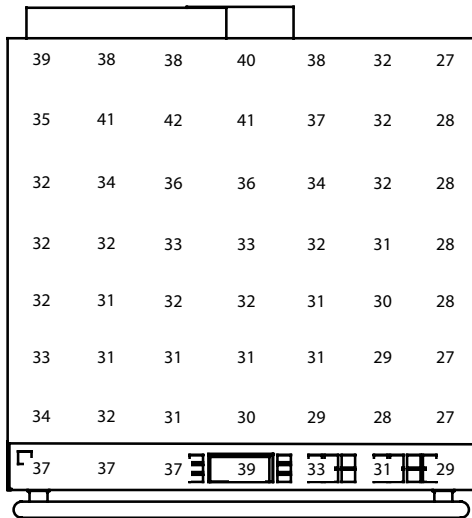
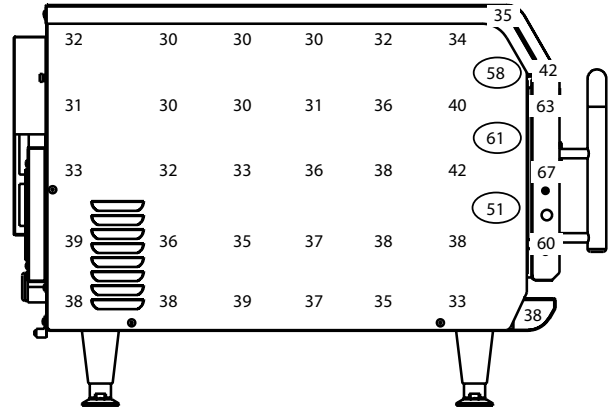
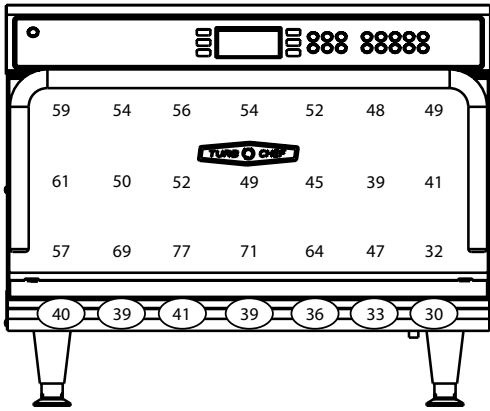

After Four-Hour Idle, Then Two Hours of Cooking (Celsius)

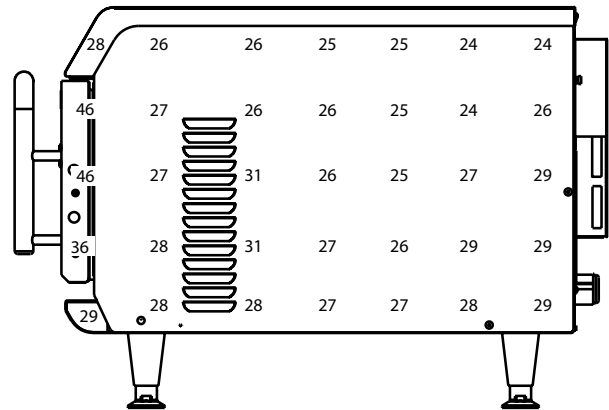
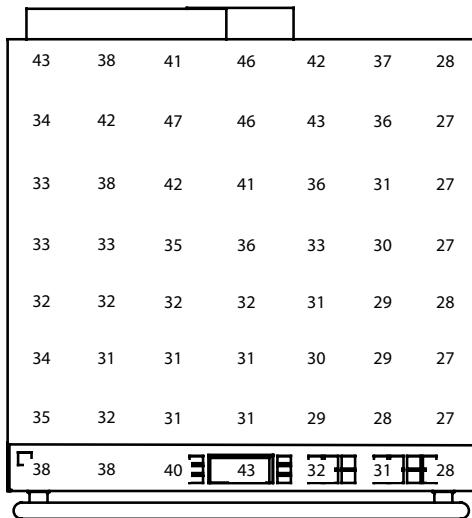
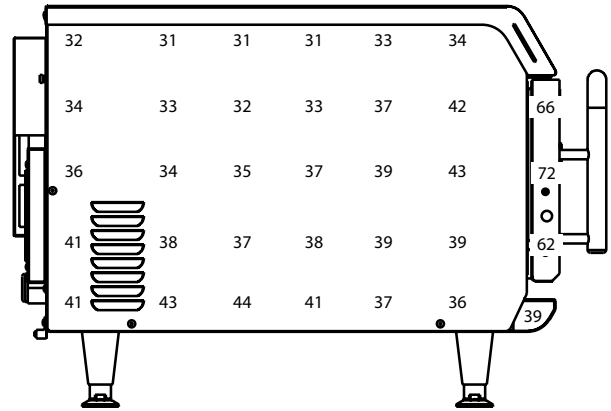
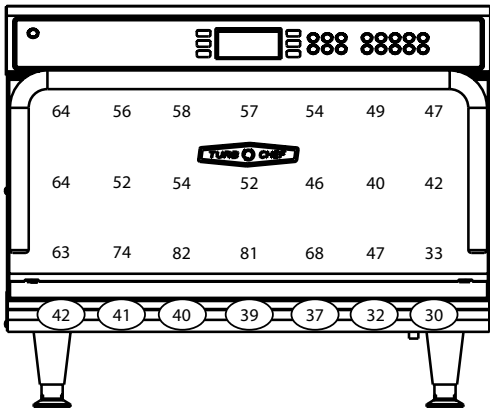

Installation Recommendations

TurboChef ventless ovens have internal systems for destroying grease laden vapor prior to the grease escaping the oven; therefore, the ovens are certified as non-grease emitting appliances. When following our recommendations, TurboChef ovens can be installed without the aid of a Type I or Type II hood per International Mechanical Code (2006, 2009, and 2012), NFPA 96, NFPA 101 (Life Safety Code), EPA 202, and Underwriter’s Laboratory (UL KNLZ).

The following guide is intended to give relevant information for the ventless installation, operation, and maintenance of TurboChef ovens. It is important that these guidelines are followed and that the oven and surrounding areas be maintained regularly for optimal performance.

Certifications

Safety – cULus, TUV (CE)
 Sanitation – NSF, UL EPH^{*}
 Ventless – UL (KNLZ)



Electrical Requirements

TurboChef ovens must be installed on a circuit equal to the ratings listed below, per NEC sec 210.23, permissible loads.

Oven	Voltage	Current	Phase
Söta (i1)	208/240 VAC	30 amp	1 Ph
Söta Single Mag (i1)	208/240 VAC	20 amp	1 Ph
i3	208/240 VAC	40 amp	1 Ph
	208/240 VAC	30 amp	3 Ph
i5	208/240 VAC	50 amp	1 Ph
	208/240 VAC	30 amp	3 Ph
Encore/Encore 2	208/240 VAC	30 amp	1 Ph
Tornado	208/240 VAC	30 amp	1 Ph
C3	208/240 VAC	50 amp	1 Ph
HhC 2620	208/240 VAC	50 amp	3 Ph
HhC 2020	208/240 VAC	50 amp	3 Ph
HhC 1618	208/240 VAC	30 amp	3 Ph
	208/240 VAC	50 amp	1 Ph
HhB 2	208/240 VAC	30 amp	1 Ph
Double Batch	208/240 VAC	50 amp	1 Ph
	208/240 VAC	30 amp	3 Ph
Waterless Steamer (i1)	208/240 VAC	30 amp	1 Ph
Panini (i1)	208/240 VAC	30 amp	1 Ph
Fire	208/240 VAC	30 amp	1 Ph
Bullet	208/240 VAC	30 amp	1 Ph

* NSF certification applies to the Tornado, C3, and HhB 2 ovens only. UL EPH certification applies to all ovens except the C3.

Menu Requirements

TurboChef ovens have been approved by Underwriter’s Laboratory for ventless operation (UL KNLZ listing) for all food items EXCEPT for foods classified as “fatty raw proteins.” Such foods include bone-in, skin-on chicken, raw hamburger meat, raw bacon, raw sausage, steaks, etc.

The TurboChef certification includes precooked food items such as pizza toppings, sandwich meats, frozen appetizers, and cheeses. Additionally, raw, lean meats such as boneless, skinless chicken breasts and fish fall within the certification.

Cleaning Requirements

To ensure continued compliance with all health, building, and fire codes, users are required to:

- Use only TurboChef-approved cleaning chemicals.
- Follow monthly and quarterly cleaning instructions provided in the manual. Post cleaning instructions near the oven.
- Ventless installation requires that the areas around the oven (walls, ceilings, kitchen equipment, etc.) be cleaned as needed but no less than once every other month.

Installation Near Open Heat Source

When placing a TurboChef oven near an open heat source (see illustration below), strictly adhere to the following:

- If the oven is being placed near a grill or stove, a divider must exist between the oven and the open heat source, with a minimum of 6” (152 mm) between the oven and the divider.
- If the oven is being placed near a fryer, a divider must exist between the oven and fryer, with a minimum of 12” (305 mm) between the oven and the divider.
- The height of the divider must be greater than or equal to the height of the oven.

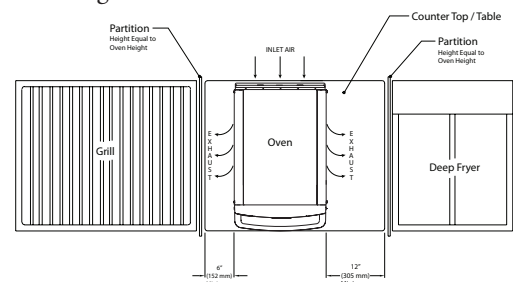

Oven Clearances

Verify the oven location has the following clearances on the top and each side. TurboChef ovens have built-in back bumpers that allow for the necessary spacing from the oven to the back wall.

Oven	Top	Sides
Sóta / Sóta Single Mag (i1)	5" (127 mm)	2" (51 mm)
i3	19" (483 mm)	2" (51 mm)
i5	19" (483 mm)	2" (51 mm)
Encore/Encore 2	5" (127 mm)	2" (51 mm)
Tornado	4" (102 mm)	2" (51 mm)
C3	4" (102 mm)	2" (51 mm)
HhC 2620	10" (254 mm)	0" (0 mm)
HhC 2020	10" (254 mm)	0" (0 mm)
HhC 1618	10" (254 mm)	0" (0 mm)
HhB 2	2" (51 mm)	2" (51 mm)
Double Batch	2" (51 mm)	2" (51 mm)
Waterless Steamer (i1)	5" (127 mm)	2" (51 mm)
Panini (i1)	5" (127 mm)	2" (51 mm)
Fire	2" (51 mm)	2" (51 mm)
Bullet	5" (127 mm)	2" (51 mm)

Ventilation

TurboChef ovens must be installed in a well-ventilated space. The space should have an exhaust rate of .70 cfm per square foot of kitchen space and an additional 100 sq. ft. (9.3 m²) of virtual space per ventless cooking appliance (TurboChef or any other).

If the air inlet is for general exhaust, pursuant to requirements for 507.2.2, paragraph 2, locate the air inlet above the center point of each oven.

The heat load from TurboChef ovens is mostly sensible. The only latent heat present is due to evaporation during the cooking process. When installing a TurboChef oven, the space must have the following tons of AC per oven installed.

Oven	Tons of AC
Sóta (i1)	0.29
Sóta Single Mag (i1)	0.29
i3	0.94
i5	1.31
Encore/Encore 2	0.45
Tornado	0.58
C3	0.63
HhC 2620	1.82
HhC 2020	1.47
HhC 1618	1.00
HhB 2	0.84
Double Batch	1.04
Waterless Steamer (i1)	0.29
Panini (i1)	0.29
Fire	0.50
Bullet	0.13

How the Ovens are Tested

TurboChef ovens are evaluated according to UL. The evaluation entails placing the test oven in an environmental chamber built to capture all emissions escaping during idle, cooking, and door-open conditions. During the eight-hour test period, a typical worst-case food item is cooked continuously, and 100% of condensable and non-condensable emissions from the product are collected and analyzed according to the EPA 202 Test Method. At the conclusion of the test, the total concentration of particulate matter (emissions) must be less than 5.0 mg/m³ for the oven to be certified for ventless operation. Cooking devices that measure above the 5.0 mg/m³ threshold are considered to produce grease and must be installed under Type I ventilation, according to International Mechanical Code.

TurboChef ovens are well below the 5.0 mg/m³ threshold as shown below.

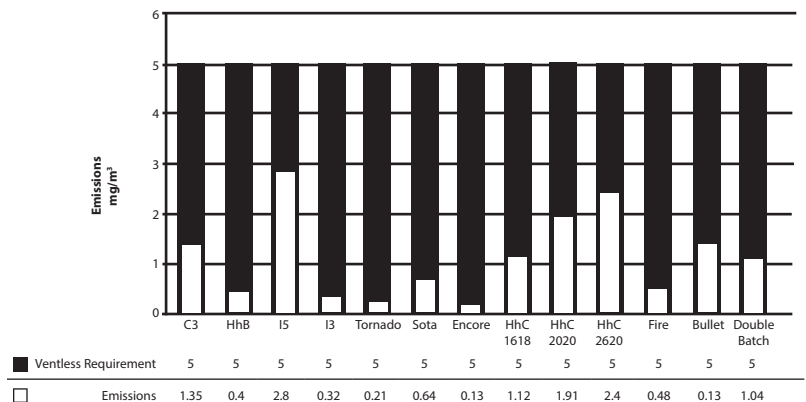

NOTE: Certain configurations of TurboChef ovens, such as a triple stacked HhC 2620, may cause emissions to be greater than 5.0 mg/m³. In these situations, TurboChef recommends that the ovens be installed under a Type I or Type II hood.

Contact Information

For questions regarding a ventless installation, email ventless.help@turbochef.com. For questions or concerns regarding an existing installation, contact Customer Service at 1.800.908.8726, Option 1.